

HS-F1000-85AB Technical Data Sheet

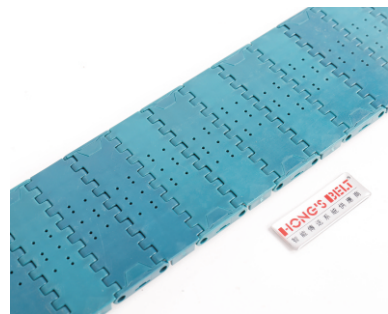
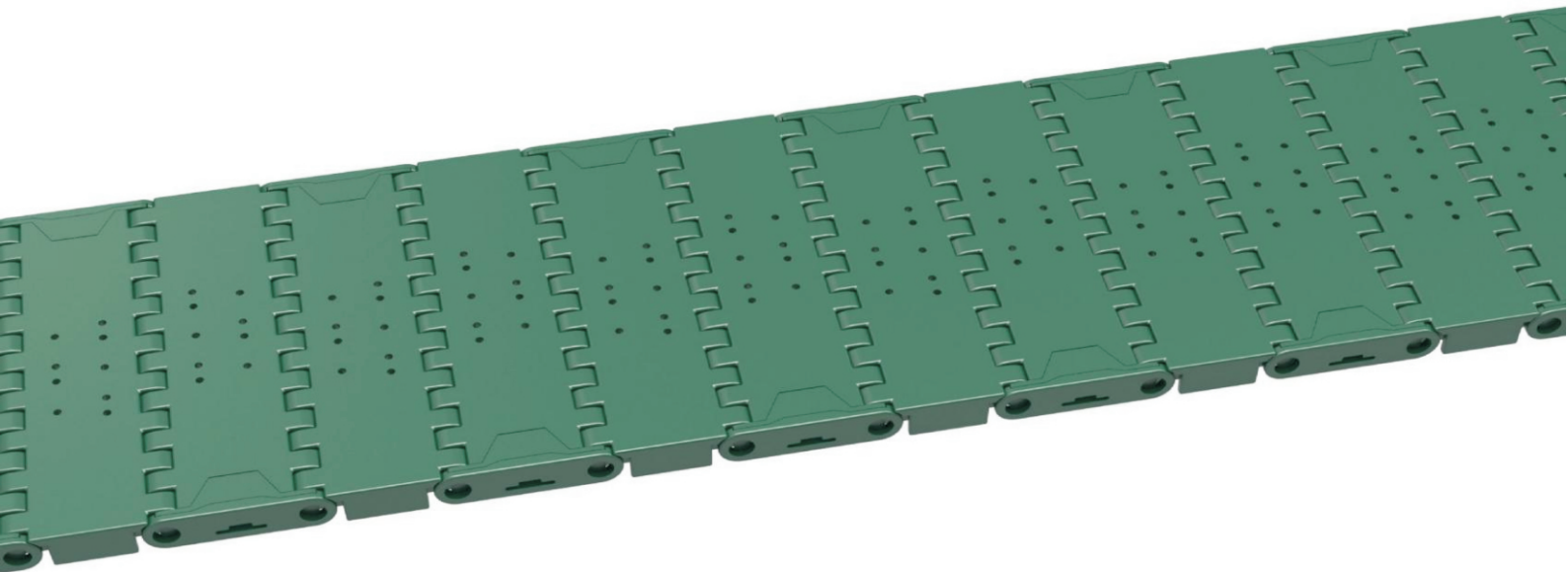

<p>Pitch: 25.4mm Minimum Width: 85mm Open Area: 1% Approved: FDA Rod: Ø 4.5mm Flight: No Side Guard: No Curve: No</p>	
--	--

Data

Belt Material	Belt Strength			Temperature		Belt Weight
	Straight		Curve	°C (min.)	°C (max.)	(Kg/M)
	Kg/M(BW)	N/M(BW)				
Acetal	2200	22000	--	-40	80	0.58

BW – Belt Width

Color Table

Polypropylene					Polyethylene					Acetal					Nylon				
W	G	N	DB	B	W	G	N	DB	B	W	G	N	DB	B	W	G	N	DB	B

W-White, G-Gray, N-Nature, DB-Dark brown, B-Blue (For more information of belt color, pls consult our sales team)

Friction Table

Belt Material	Friction Wear strips & Products							
	UHMW	HDPE	Steel	Glass	SUS	Plastic	Cardboard	Aluminum
Polypropylene	0.32	0.24	0.15	0.09	0.13	0.08	0.15	0.25
Polyethylene	0.13	0.11	0.26	0.19	0.31	0.16	0.21	0.41
Acetal	0.11	0.09	0.27	0.16	0.26	0.15	0.19	0.28
Nylon	0.18	0.13	0.25	0.16	0.26	0.16	0.19	0.27

SUS – Stainless Steel

Equivalent type with other Brand

Brand Name	Intralox	Habasit	UNI	Renxord	MCC	ScanBelt
Series & Type	--	--	--	--	--	--

The above content is only for reference.

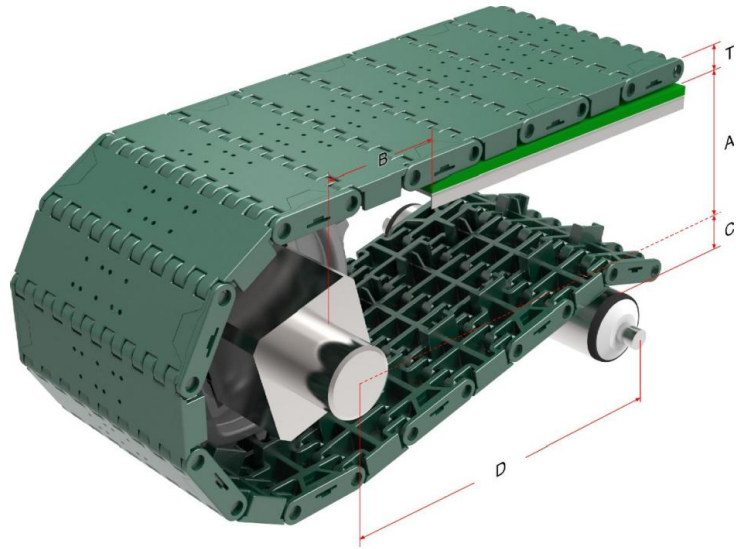

Conveyor Frame Dimensions

Unit : mm

No. Teeth	A (Min.)	B (Min.)	C (Max.)	D (Min.)	T
12-2R	44	59	44	200	8.6
18-2R	70	84	70	200	
20-2R	78	93	78	200	

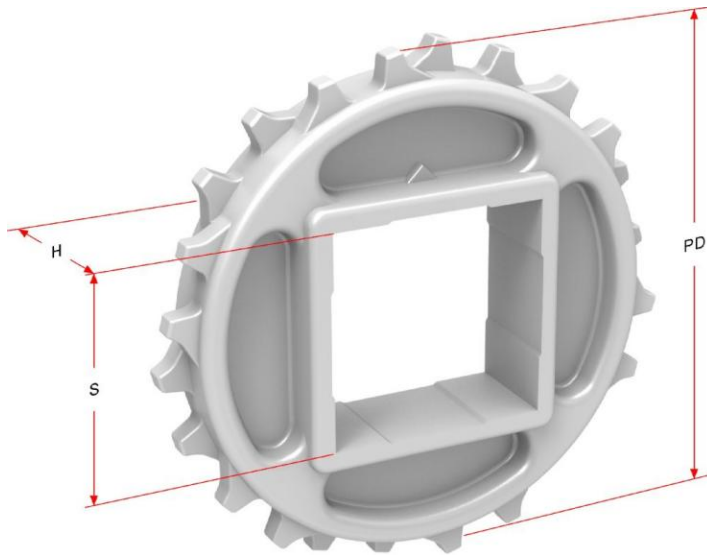

Sprocket Dimensions

Unit: mm

No. Teeth	PD	OD	S	D	H	K
12-2R	98.14	97	38.1/40	30	20	8X8
18-2R	146.27	148	38.1/40/60	25/30/40/50	20	8X8
20-2R	162.37	165	40/60	50	20	14X9