

## HS-902B Technical Data Sheet

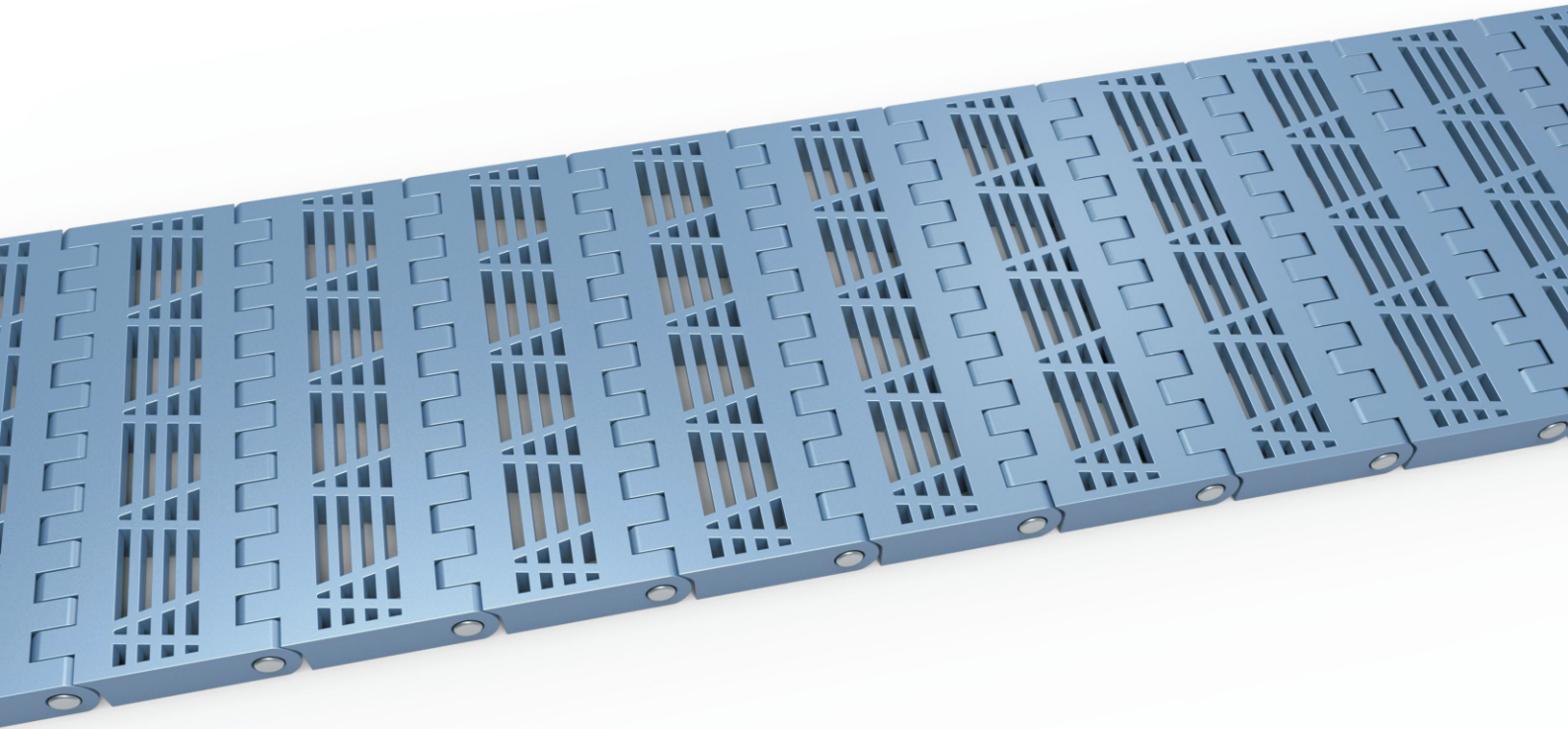

<p>Pitch: 50.8mm                  Minimum Width: 150.8mm                  Open Area: 23%                  Approved: FDA                  Rod: Ø 8.0mm                  Flight: Yes                  Side Guard: No                  Curve: No</p>	
---	--

## Data

Belt Material	Belt Strength			Temperature		Belt Weight (Kg/M <sup>2</sup> )
	Straight		Curve	°C (min.)	°C (max.)	
	Kg/M(BW)	N/M(BW)				
Polypropylene	1340	13400	--	1	100	9.3
Polyethylene	1280	12800	--	-60	60	9.8
Acetal	1770	17700	--	-40	80	14.0
Nylon	1520	15200	--	1	180	12.6

BW – Belt Width

## Color Table

Polypropylene					Polyethylene					Acetal					Nylon				
W	G	N	DB	B	W	G	N	DB	B	W	G	N	DB	B	W	G	N	DB	B
●	●						●			●			●	●				●	

W-White, G-Gray, N-Nature, DB-Dark brown, B-Blue (For more information of belt color, pls consult our sales team)

## Friction Table

Belt Material	Friction Wear strips & Products							
	UHMW	HDPE	Steel	Glass	SUS	Plastic	Cardboard	Aluminum
Polypropylene	0.32	0.24	0.15	0.09	0.13	0.08	0.15	0.25
Polyethylene	0.13	0.11	0.26	0.19	0.31	0.16	0.21	0.41
Acetal	0.11	0.09	0.27	0.16	0.26	0.15	0.19	0.28

SUS – Stainless Steel

## Equivalent type with other Brand

Brand Name	Intralox	Habasit	UNI	Rexnord	MCC	ScanBelt
Series & Type	--	--	OPB	--	--	--

The above content is only for reference.

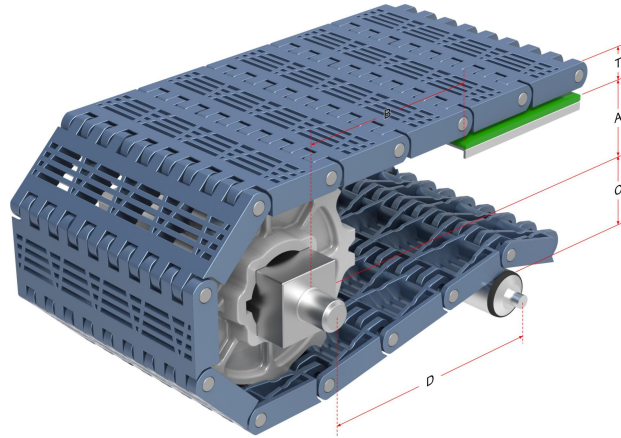

**Conveyor Frame Dimensions**

Unit : mm

No. Teeth	A ( Min.)	B ( Min.)	C ( Max.)	D ( Min.)	T
7	48.4	66.4	44.4	250	16
8	56	74	52	250	
9	65	83	61	250	
10	73	91	69	250	

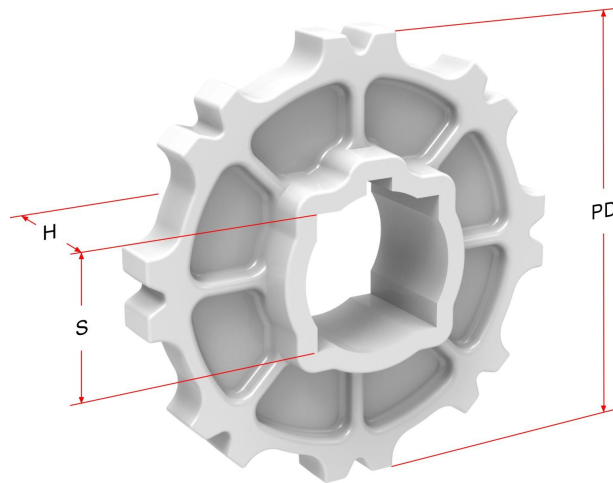

**Sprocket Dimensions**

Unit: mm

No. Teeth	PD	OD	S	D	H	K
7	117.08	112.8	38.1/40	45/47	35	8X8
8	132.75	128	38.1/40	45/47	35	8X8
9	148.53	146	38.1/40/50	35/40/45	35	12X8
10	164.39	162	38.1/40	45/47	35	8X8