

HS-901B Technical Data Sheet

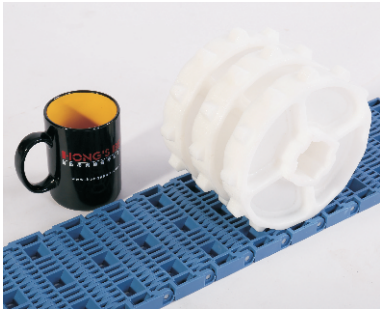
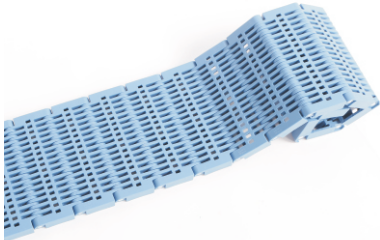
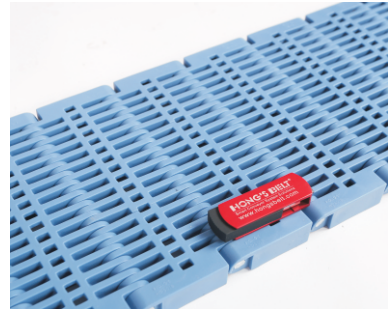
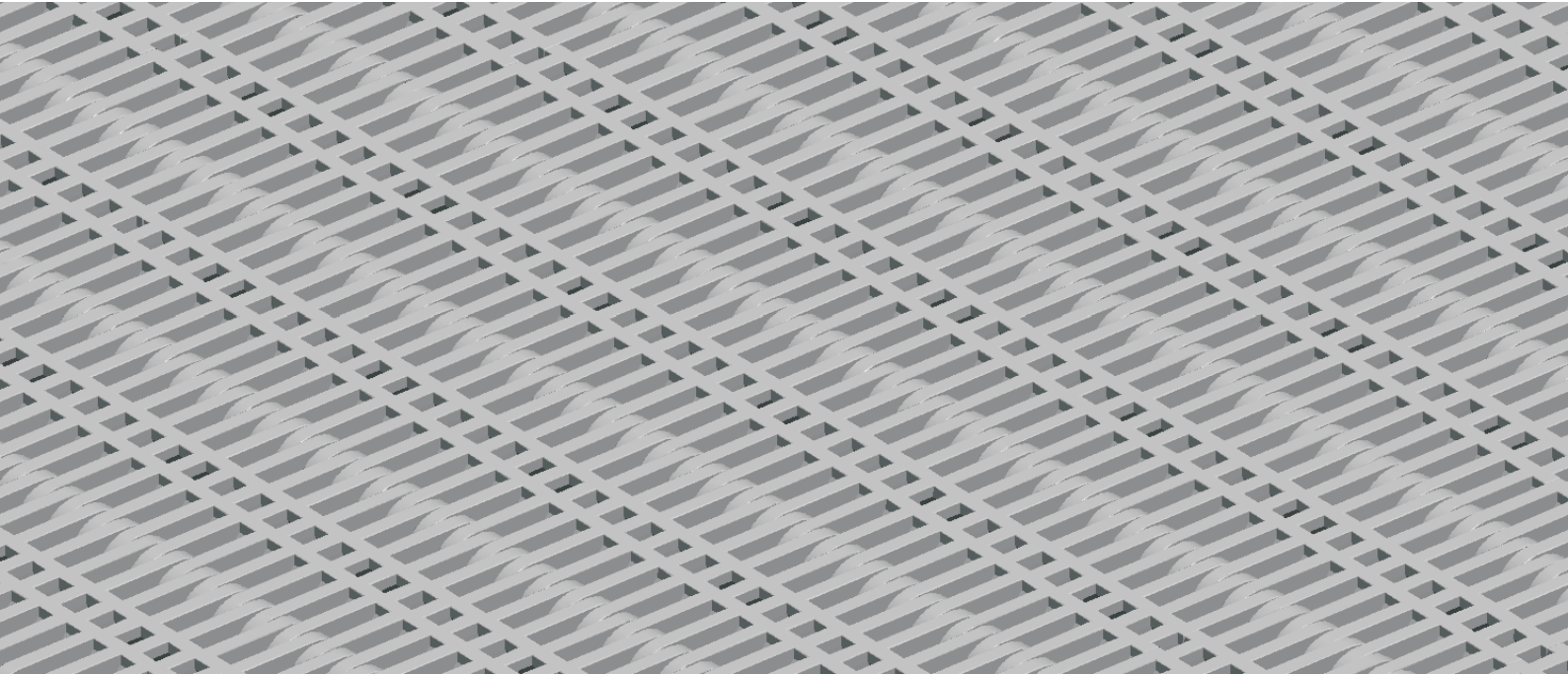

<p>Pitch: 50.8mm Minimum Width: 152mm Open Area: 18% Approved: FDA Rod: Ø 5.8mm Flight: Yes Side Guard: No Curve: No</p>	
---	--

Data

Belt Material	Belt Strength			Temperature		Belt Weight (Kg/M ²)
	Straight		Curve	°C (min.)	°C (max.)	
	Kg/M(BW)	N/M(BW)				
Polypropylene	3500	35000	--	1	100	8.4
Polyethylene	2600	26000	--	-60	60	9.3
Acetal	4760	47600	--	-40	80	13.6

BW – Belt Width

Color Table

Polypropylene					Polyethylene					Acetal					Nylon				
W	G	N	DB	B	W	G	N	DB	B	W	G	N	DB	B	W	G	N	DB	B
●	●						●			●			●	●					

W-White, G-Gray, N-Nature, DB-Dark brown, B-Blue (For more information of belt color, pls consult our sales team)

Friction Table

Belt Material	Friction Wear strips & Products							
	UHMW	HDPE	Steel	Glass	SUS	Plastic	Cardboard	Aluminum
Polypropylene	0.32	0.24	0.15	0.09	0.13	0.08	0.15	0.25
Polyethylene	0.13	0.11	0.26	0.19	0.31	0.16	0.21	0.41
Acetal	0.11	0.09	0.27	0.16	0.26	0.15	0.19	0.28

SUS – Stainless Steel

Equivalent type with other Brand

Brand Name	Intralox	Habasit	UNI	Rexnord	MCC	ScanBelt
Series & Type	--	--	--	--	--	--

The above content is only for reference.

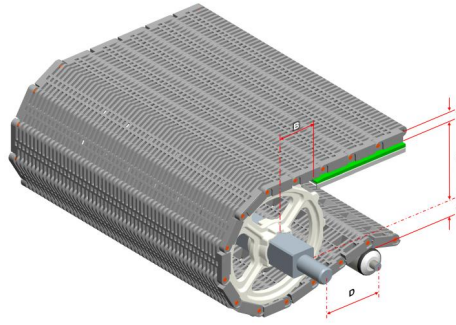

Conveyor Frame Dimensions

Unit : mm

No. Teeth	A (Min.)	B (Min.)	C (Max.)	D (Min.)	T
6	37.5	55.5	33.5	200	16
8 / 8-Split	56.5	74.5	52.5	250	
10 / 10-Split	72	90	68	250	
12 / 12-Split	90	108	86	300	
13	100.2	118.2	96.2	300	
16	121.75	139.75	117.75	300	
17	130	148	126	300	

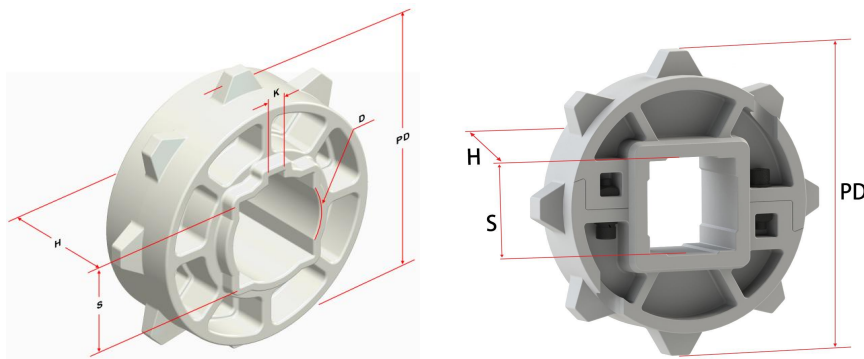

Sprocket Dimensions

Unit: mm

No. Teeth	PD	OD	S	D	H	K
6	101.60	91	38.1	--	38	--
8	132.75	129	35/40	--	28/38	--
8-Split	132.75	129	38.1/40	--	38	--
10	164.39	160	38.1/40/50/60/63.5/70	47/50.8	49	8X8
10-Split	164.39	160	38.1/40/60	--	38	--
12	196.28	196	38.1/40/50/60/63.5/70	40	49	12X8
12-Split	196.28	196	38.1	--	38	--
13	212.27	216.37	60	--	38	--
16	260.39	259.5	60/80/90	---	49	---
17	276.46	276	120	--	49	--

Note: Thickness 28mm is only for 8T-S40.