

## HS-900B Technical Data Sheet

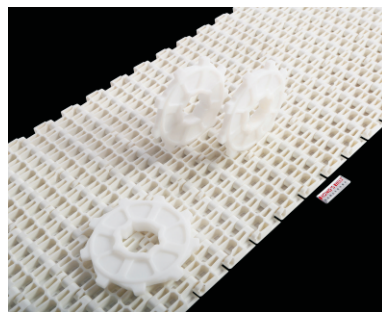
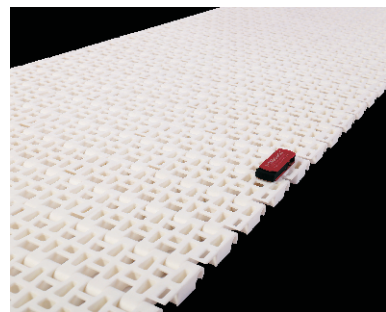
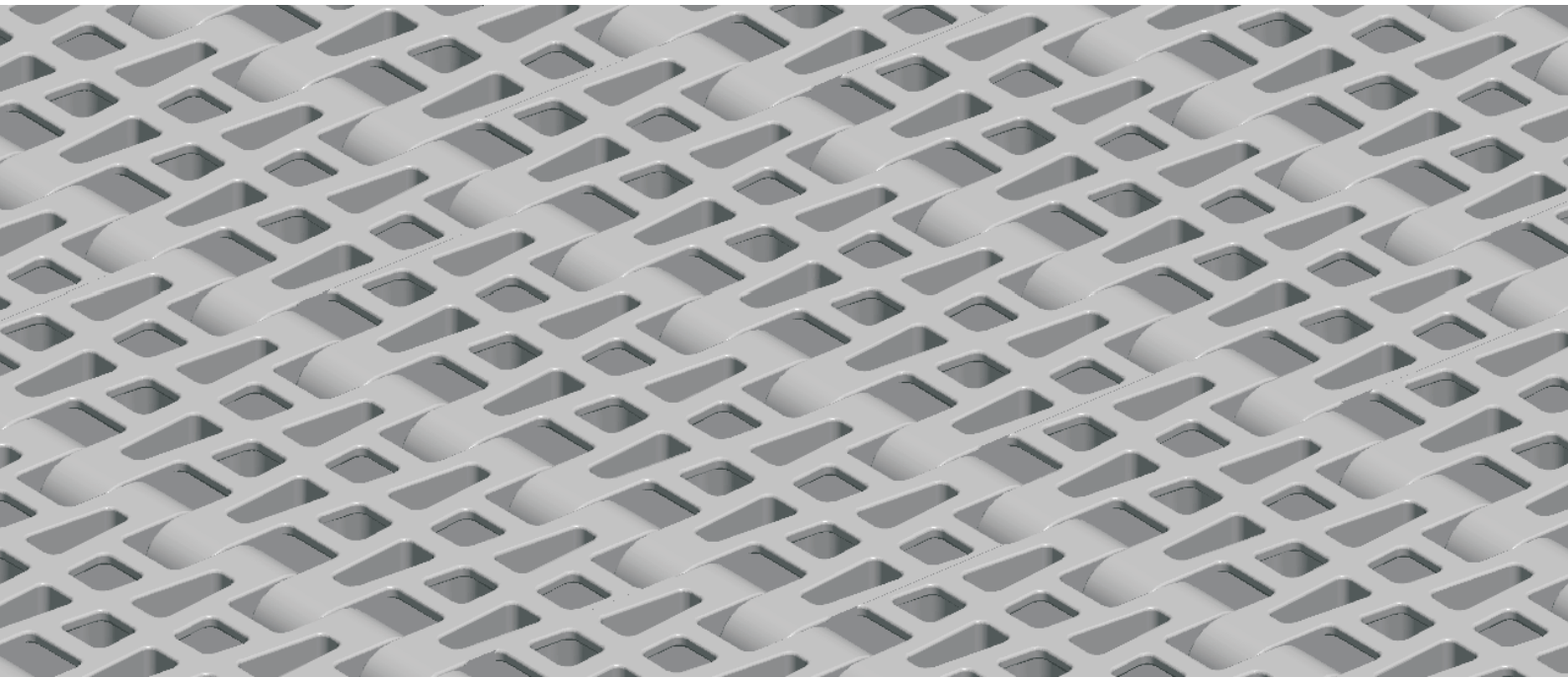

Pitch: 50.8mm Minimum Width: 150mm Open Area: 34% Approved: FDA Rod: Ø 5.8mm Flight: Yes Side Guard: No Curve: No	
--	--

## Data

Belt Material	Belt Strength			Temperature		Belt Weight (Kg/M <sup>2</sup> )
	Straight		Curve	°C (min.)	°C (max.)	
	Kg/M(BW)	N/M(BW)				
Polypropylene	2745	27450	--	1	100	6.0
Polyethylene	2610	26100	--	-60	60	6.1
Acetal	3090	30900	--	-40	80	9.4
Nylon	2400	24000	--	1	180	7.8

**BW – Belt Width**

## Color Table

Polypropylene					Polyethylene					Acetal					Nylon				
W	G	N	DB	B	W	G	N	DB	B	W	G	N	DB	B	W	G	N	DB	B
●	●						●			●						●			

W-White, G-Gray, N-Nature, DB-Dark brown, B-Blue (For more information of belt color, pls consult our sales team)

## Friction Table

Belt Material	Friction Wear strips & Products							
	UHMW	HDPE	Steel	Glass	SUS	Plastic	Cardboard	Aluminum
Polypropylene	0.32	0.24	0.15	0.09	0.13	0.08	0.15	0.25
Polyethylene	0.13	0.11	0.26	0.19	0.31	0.16	0.21	0.41
Acetal	0.11	0.09	0.27	0.16	0.26	0.15	0.19	0.28
Nylon	0.18	0.13	0.25	0.16	0.26	0.16	0.19	0.27

SUS – Stainless Steel

## Equivalent type with other Brand

Brand Name	Intralox	Habasit	UNI	Rexnord	MCC	ScanBelt
Series & Type	--	M5033	--	--	--	--

The above content is only for reference.

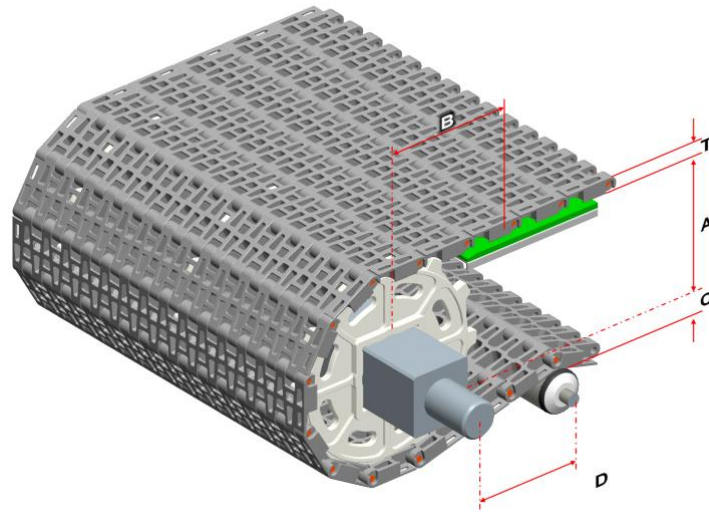

## Conveyor Frame Dimensions

Unit : mm

No. Teeth	A ( Min.)	B ( Min.)	C ( Max.)	D ( Min.)	T
6	41	58	38	250	14
9	66.5	83.5	63.5	250	
12	90.75	107.75	87.75	300	

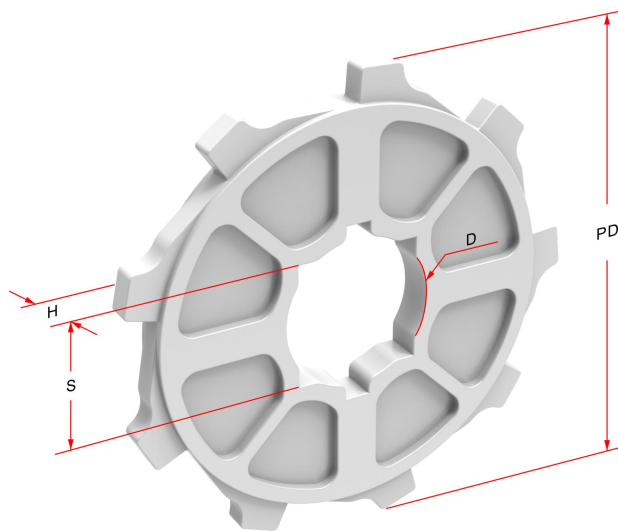

## Sprocket Dimensions

Unit: mm

No. Teeth	PD	OD	S	D	H	K
6	101.60	96	38.1/40	45/47	20	7X7
9	148.53	147	38.1/40/50	25.4/30/31.75/40/47/50	12	8X8
12	196.28	195.5	38.1/40/60/63.5	--	12	--