

HS-900B-HD Technical Data Sheet

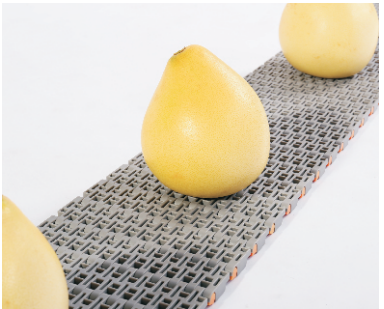
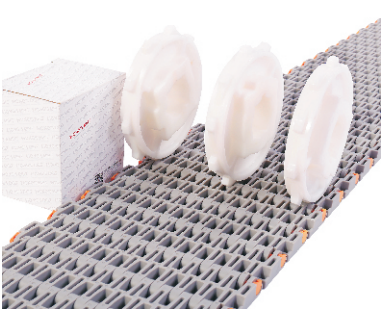
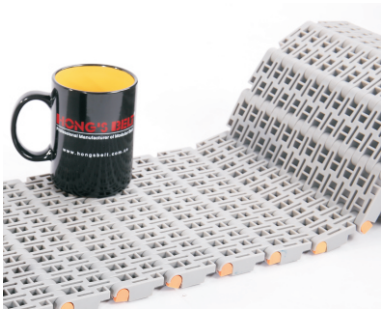
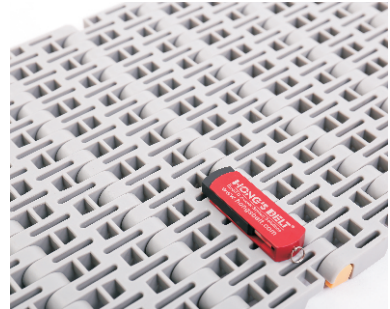
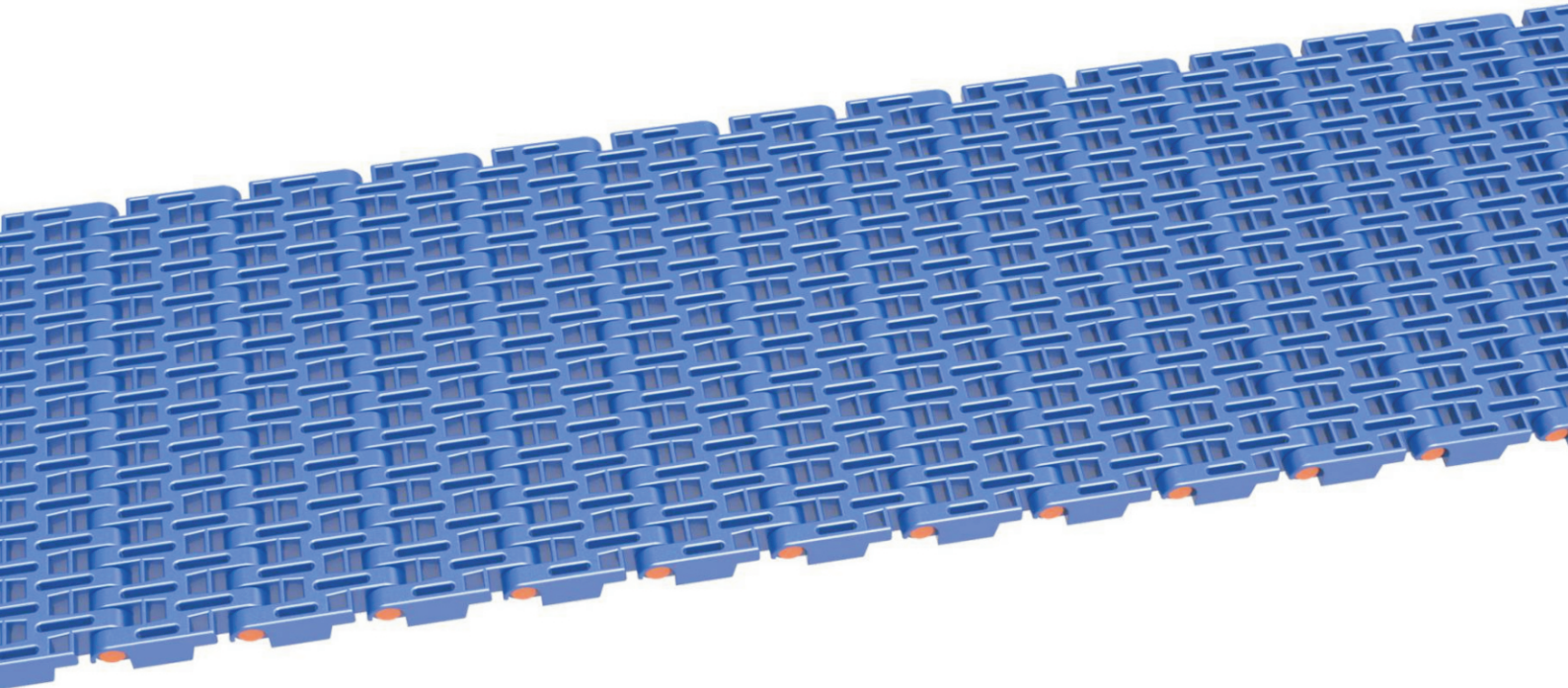

Pitch: 50.8mm Minimum Width: 223mm Open Area: 32% Approved: FDA Rod: Ø 7.0mm Flight: Yes Side Guard: No Curve: No	
--	--

Data

Belt Material	Belt Strength			Temperature		Belt Weight (Kg/M ²)
	Straight		Curve	°C (min.)	°C (max.)	
	Kg/M(BW)	N/M(BW)				
Polypropylene	2745	27450	--	1	110	8.2
Polyethylene	2610	26100	--	-60	60	8.6
Acetal	3090	30900	--	-40	80	12.4
Nylon	2400	24000	--	1	180	11.2

BW – Belt Width

Color Table

Polypropylene					Polyethylene					Acetal					Nylon				
W	G	N	DB	B	W	G	N	DB	B	W	G	N	DB	B	W	G	N	DB	B
●	●						●			●						●			

W-White, G-Gray, N-Nature, DB-Dark brown, B-Blue (For more information of belt color, pls consult our sales team)

Friction Table

Belt Material	Friction Wear strips & Products							
	UHMW	HDPE	Steel	Glass	SUS	Plastic	Cardboard	Aluminum
Polypropylene	0.32	0.24	0.15	0.09	0.13	0.08	0.15	0.25
Polyethylene	0.13	0.11	0.26	0.19	0.31	0.16	0.21	0.41
Acetal	0.11	0.09	0.27	0.16	0.26	0.15	0.19	0.28
Nylon	0.18	0.13	0.25	0.16	0.26	0.16	0.19	0.27

SUS – Stainless Steel

Equivalent type with other Brand

Brand Name	Intralox	Habasit	UNI	Rexnord	MCC	ScanBelt
Series & Type	--	M5032	--	--	--	--

The above content is only for reference.

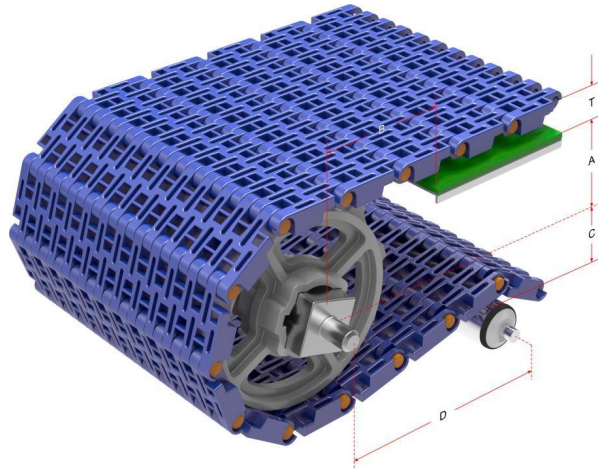

Conveyor Frame Dimensions

Unit : mm

No. Teeth	A (Min.)	B (Min.)	C (Max.)	D (Min.)	T
8	52.7	70.7	48.7	250	16
9	61.5	79.5	57.5	250	
10	70.6	88.6	66.6	300	
12	86	104	82	300	
16	120	138	116	300	

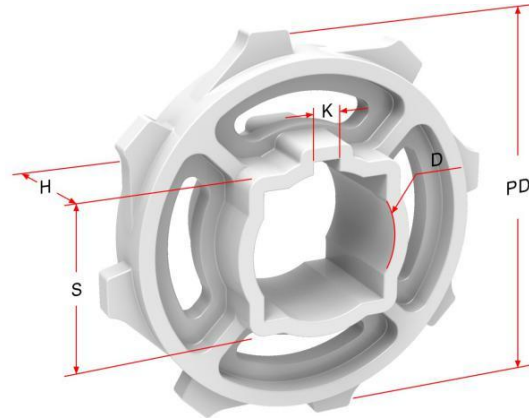
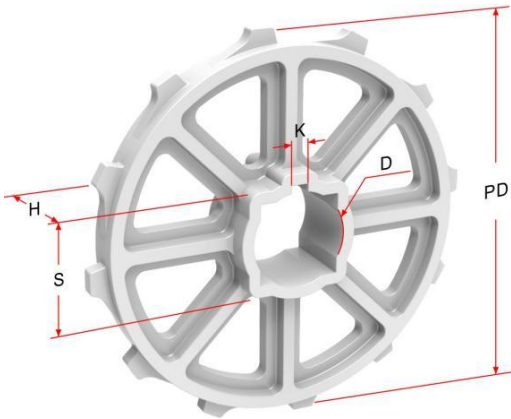

Sprocket Dimensions

Unit: mm

No. Teeth	PD	OD	S	D	H	K
8	132.75	121.4	38.1/40	--	38	--
9	148.53	139	38.1/40	--	38	--
10	164.39	157.2	38.1/40/50	65	38	18X11
12	196.28	188	38.1/40	--	38	--
16	260.39	256	90	--	38	--