

HS-800-1C Technical Data Sheet

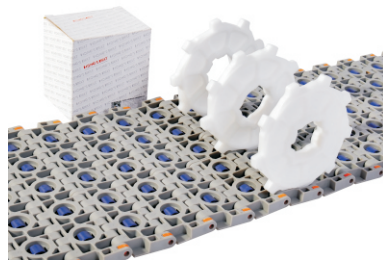
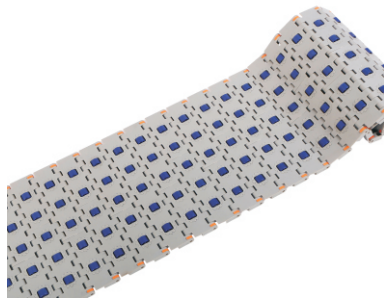
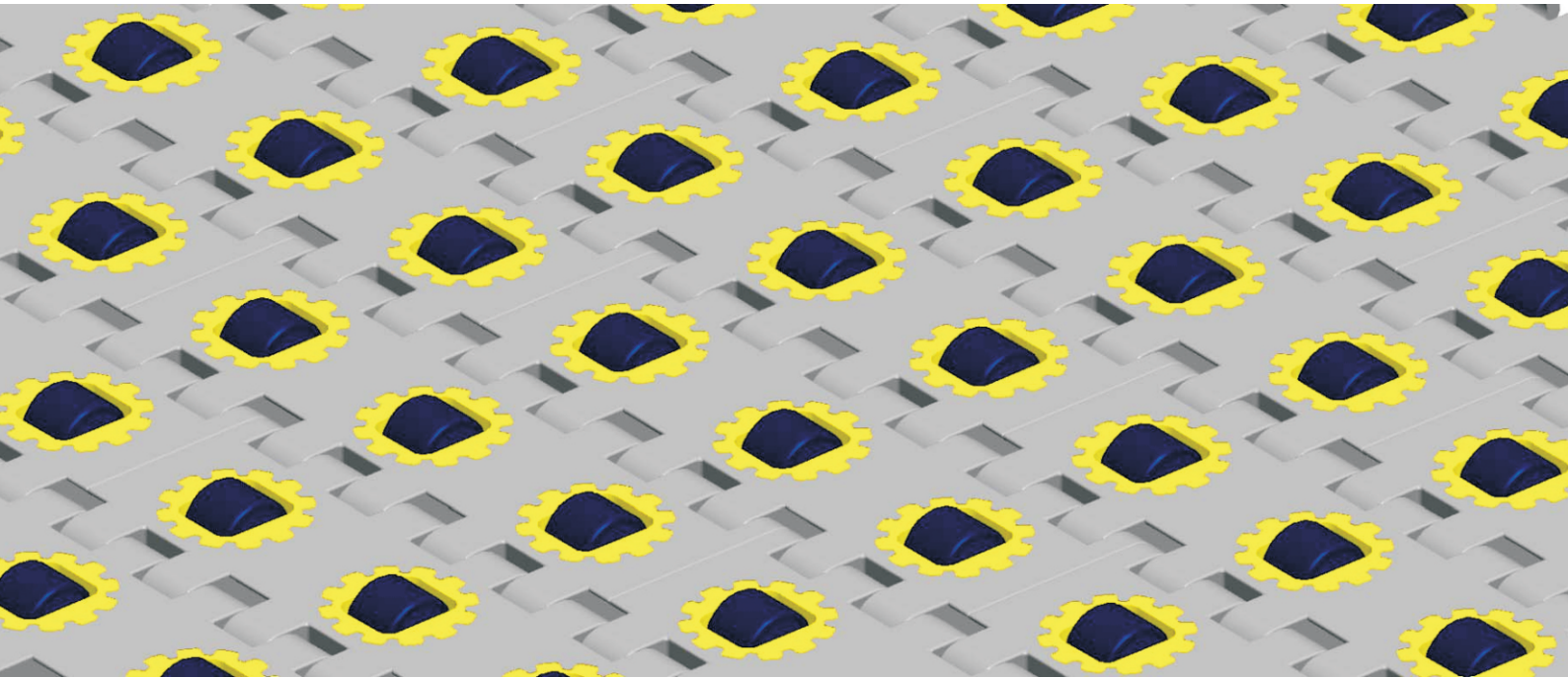

<p>Pitch: 50.8mm Minimum Width: 188mm Open Area: 0% Approved: FDA Rod: Ø 5.8mm Flight: No Side Guard: No Curve: No</p>	
---	--

Data

Belt Material	Belt Strength			Temperature		Belt Weight (Kg/M ²)
	Straight		Curve	°C (min.)	°C (max.)	
	Kg/M(BW)	N/M(BW)				
Polypropylene	4380	43800	--	1	100	9.8
BW – Belt Width						

Color Table

Polypropylene					Polyethylene					Acetal					Nylon				
W	G	N	DB	B	W	G	N	DB	B	W	G	N	DB	B	W	G	N	DB	B
●	●																		

W-White, G-Gray, N-Nature, DB-Dark brown, B-Blue (For more information of belt color, pls consult our sales team)

Friction Table

Belt Material	Friction Wear strips & Products							
	UHMW	HDPE	Steel	Glass	SUS	Plastic	Cardboard	Aluminum
Polypropylene	0.32	0.24	0.15	0.09	0.13	0.08	0.15	0.25
Polyethylene	0.13	0.11	0.26	0.19	0.31	0.16	0.21	0.41
Acetal	0.11	0.09	0.27	0.16	0.26	0.15	0.19	0.28
Nylon	0.18	0.13	0.25	0.16	0.26	0.16	0.19	0.27

SUS – Stainless Steel

Equivalent type with other Brand

Brand Name	Intralox	Habasit	UNI	Renxord	MCC	ScanBelt
Series & Type	--	--	--	--	--	--

The above content is only for reference.

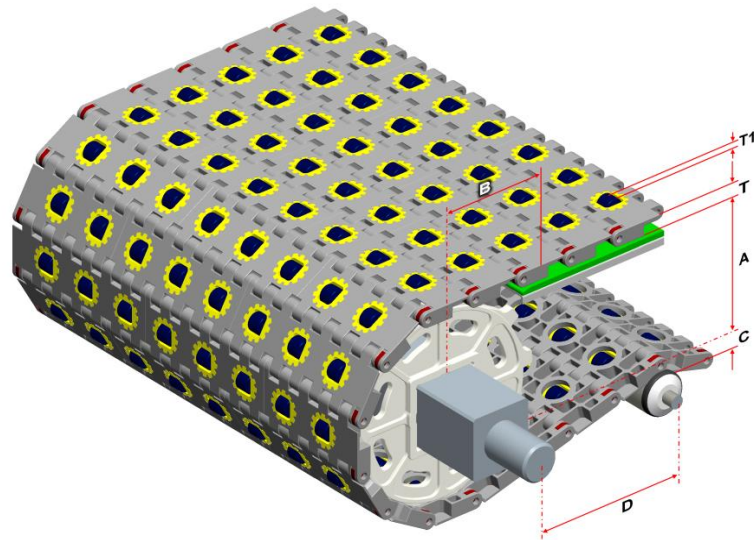

Conveyor Frame Dimensions

Unit : mm

No. Teeth	A (Min.)	B (Min.)	C (Max.)	D (Min.)	T	T2
6	41	58	38	250	14	4
9	66.5	83.5	63.5	250		
12	90.75	107.75	87.75	300		

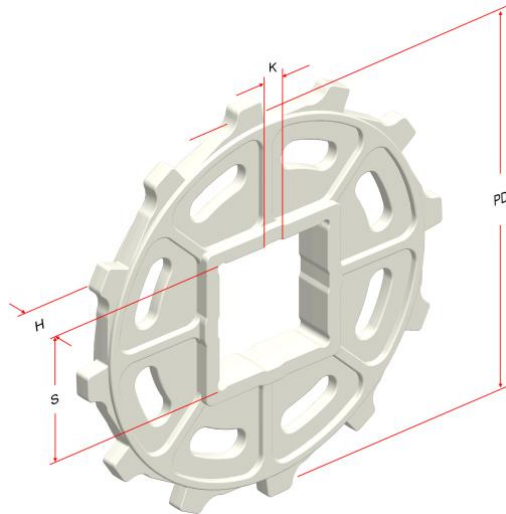

Sprocket Dimensions

Unit: mm

No. Teeth	PD	OD	S	D	H	K
6	101.60	96	38.1/40	45/47	20	7X7
9	148.53	147	38.1/40/50	25.4/30/31.75/40/47/50	12	8X8
12	196.28	195.5	38.1/40/60/63.5	--	12	--

Angled Roller:

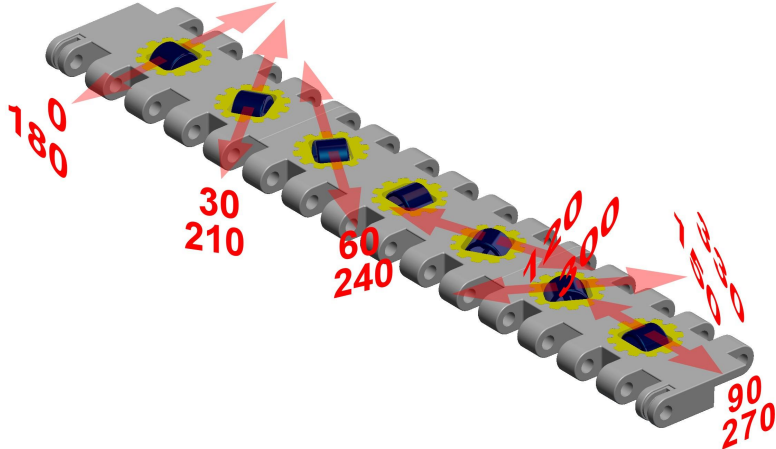

HS-800 TYPE 1C the adjustable angle unit of roll is 30 degree, 6 optional directions, just like that shown in above picture.

