

HS-750RC Technical Data Sheet

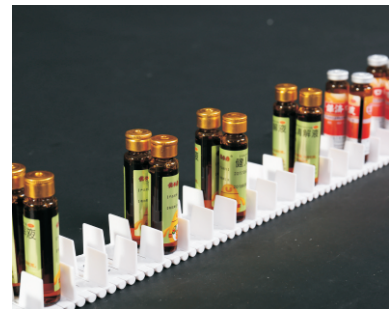
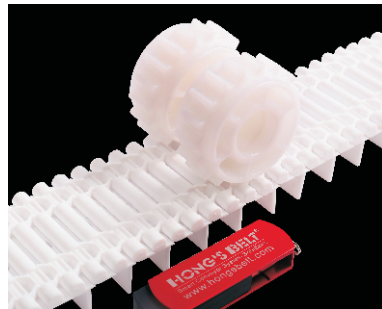
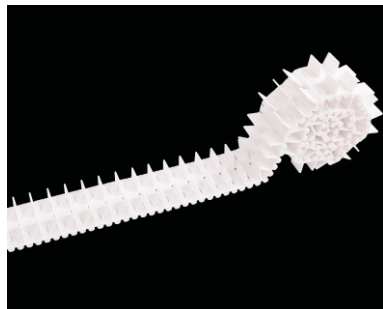
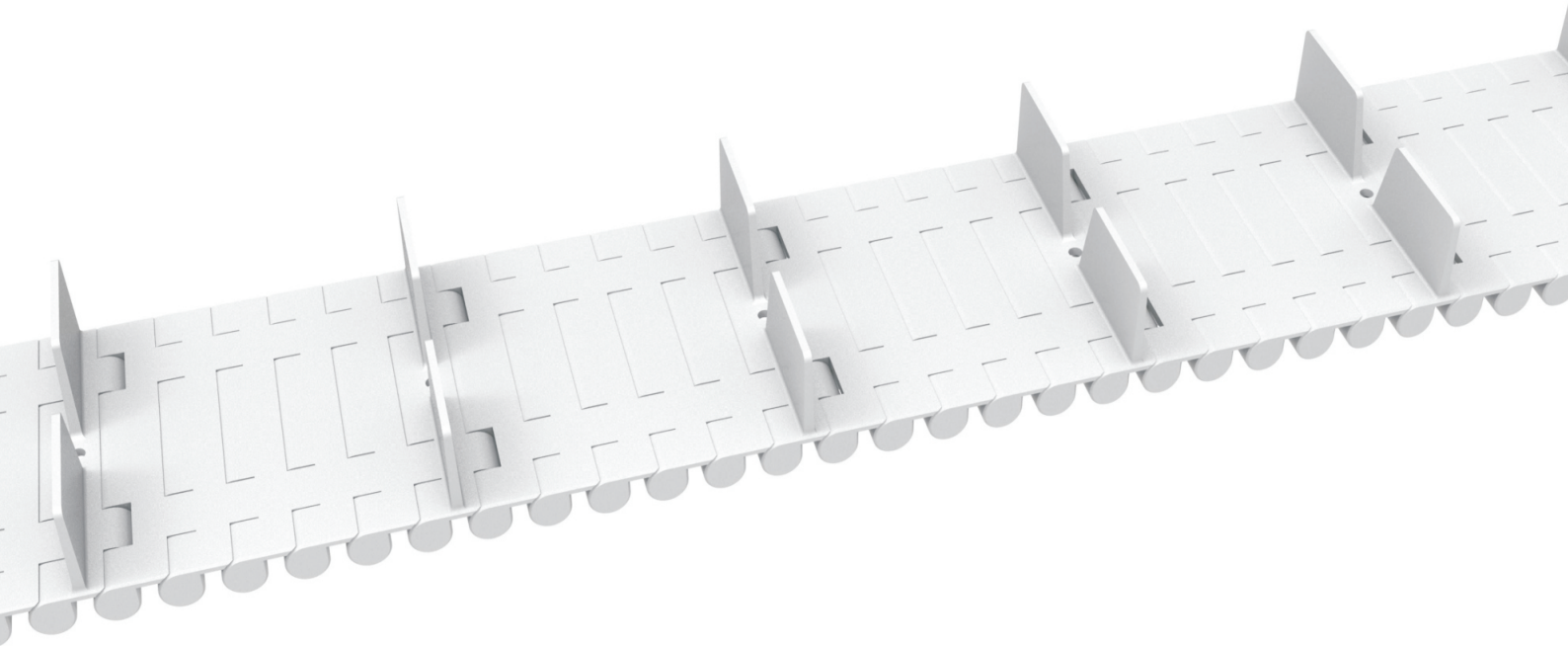
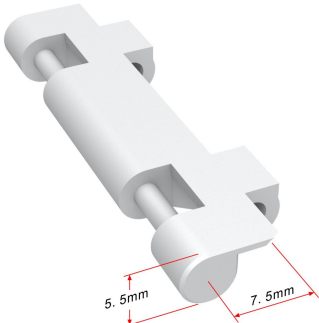

Pitch: 7.5mm Minimum Width: 46mm Open Area: 0% Approved: FDA Rod: Non Flight: Yes Side Guard: No Curve: No	
---	--

Data

Belt Material	Belt Strength		Curve	Temperature		Belt Weight (Kg/M ²)
	Straight			°C (min.)	°C (max.)	
	Kg/M(BW)	N/M(BW)				
Polypropylene	800	8000	--	1	100	0.100
Acetal	465	4650	--	-40	80	0.148

BW – Belt Width

Color Table

Polypropylene					Polyethylene					Acetal					Nylon									
W	G	N	DB	B	W	G	N	DB	B	W	G	N	DB	B	W	G	N	DB	B					
●	●									●	●								●					

W-White, G-Gray, N-Nature, DB-Dark brown, B-Blue (For more information of belt color, pls consult our sales team)

Friction Table

Belt Material	Friction Wear strips & Products							
	UHMW	HDPE	Steel	Glass	SUS	Plastic	Cardboard	Aluminum
Polypropylene	0.32	0.24	0.15	0.09	0.13	0.08	0.15	0.25
Polyethylene	0.13	0.11	0.26	0.19	0.31	0.16	0.21	0.41
Acetal	0.11	0.09	0.27	0.16	0.26	0.15	0.19	0.28
Nylon	0.18	0.13	0.25	0.16	0.26	0.16	0.19	0.27

SUS – Stainless Steel

Equivalent type with other Brand

Brand Name	Intralox	Habasit	UNI	Rexnord	MCC	ScanBelt
Series & Type	--	--	--	--	--	--

The above content is only for reference.

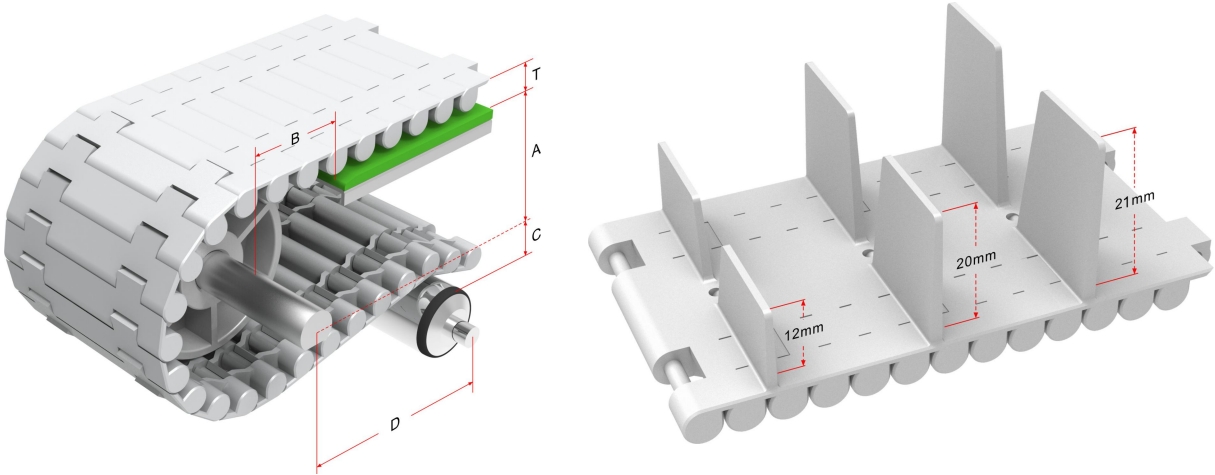

Conveyor Frame Dimensions

Unit : mm

No. Teeth	A (Min.)	B (Min.)	C (Max.)	D (Min.)	T
18	34	46	36	50	5.5

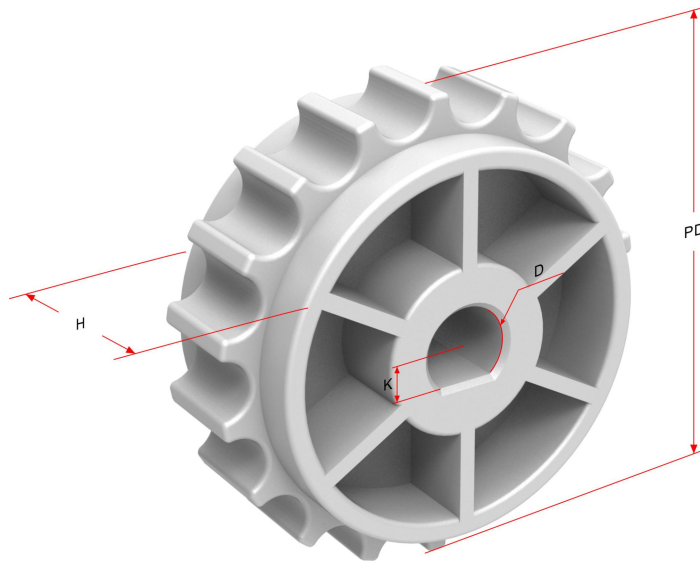

Sprocket Dimensions

Unit: mm

No. Teeth	PD	OD	D	H	K
18	43.19	44	8	19	--
18-Idler	43.19	44	14	19	--