

HS-700EL-N Technical Data Sheet

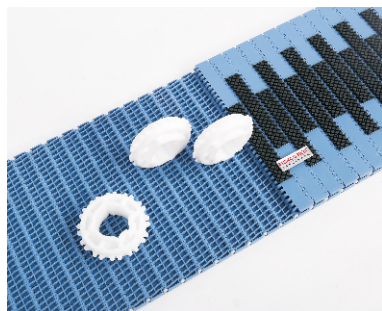
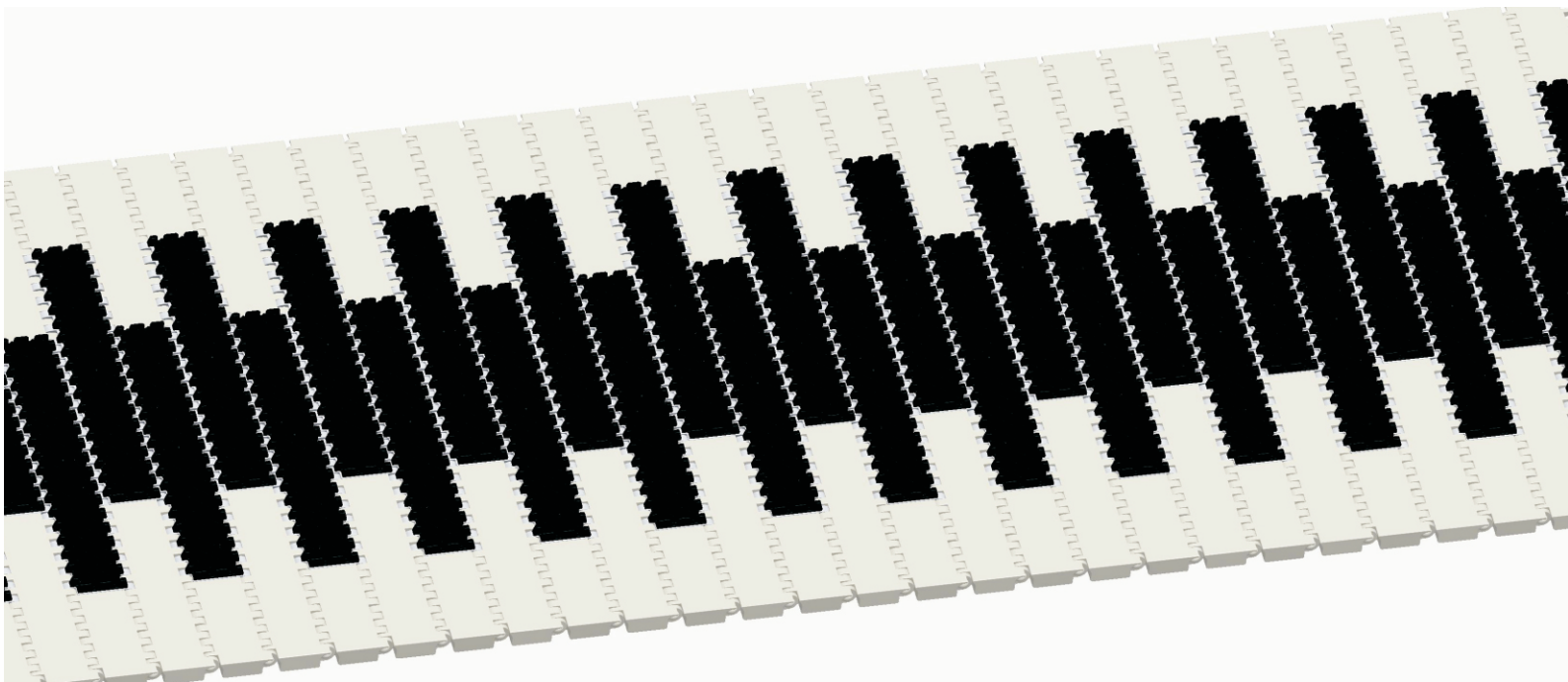

Pitch : 27.2mm Minimum Width : 152mm Open Area : 0% Approved : FDA Rod : Ø 4.5mm Flight : Yes Side Guard : No Curve : No	
---	--

Data

Belt Material	Belt Strength			Temperature		Belt Weight (Kg/M ²)
	Straight		Curve	°C (min.)	°C (max.)	
	Kg/M(BW)	N/M(BW)				
Polypropylene	1320	13200	--	1	100	7.9
Polyethylene	1060	10600	--	-60	60	8.7

BW – Belt Width

Color Table

Polypropylene					Polyethylene					Acetal					Nylon				
W	G	N	DB	B	W	G	N	DB	B	W	G	N	DB	B	W	G	N	DB	B
●	●						●												

W-White, G-Gray, N-Nature, DB-Dark brown, B-Blue

Friction Table

Belt Material	Friction Wear strips & Products							
	UHMW	HDPE	Steel	Glass	SUS	Plastic	Cardboard	Aluminum
Polypropylene	0.32	0.24	0.15	0.09	0.13	0.08	0.15	0.25
Polyethylene	0.13	0.11	0.26	0.19	0.31	0.16	0.21	0.41
Acetal	0.11	0.09	0.27	0.16	0.26	0.15	0.19	0.28
Nylon	0.18	0.13	0.25	0.16	0.26	0.16	0.19	0.27

SUS – Stainless Steel

Equivalent type with other Brand

Brand Name	Intralox	UNI	Rexnord	MCC	Habasit	KVP
Series & Type	900	SNB	1005	1000	M2400	610
	1600	CNB	1010	--	M2500	208
	200	OPB	7700	--	M2600	--
	800	--	6390	--	--	--

The above content is only for reference.

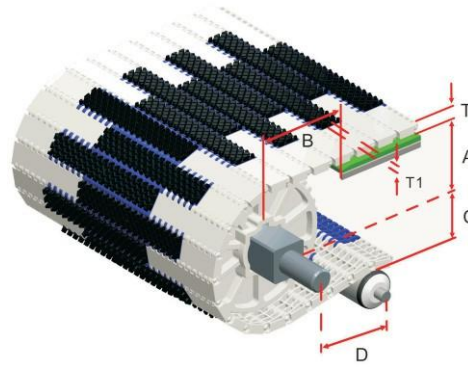

Conveyor Frame Dimensions

Unit : mm

No. Teeth	A (Min.)	B (Min.)	C (Min.)	D (Min.)	T	T1
6	21.25	36.15	20.35	200	9.8	5
9	35	49.9	34.1	200		
10	38.85	53.75	37.95	250		
12	47.85	62.75	46.95	250		
17	71.1	86.0	70.2	300		
18	74	88.9	73.1	300		
20 / 20-Split	82.6	97.5	81.7	300		
24	100	114.9	99.1	300		

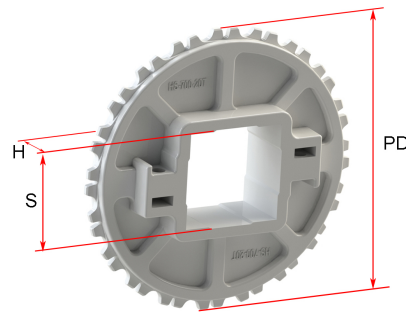
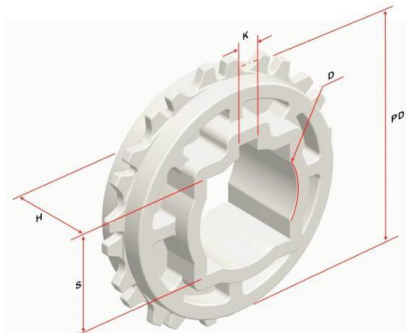

Sprocket Dimensions

Unit: mm

No. Teeth	PD	S	D	H	K
6	52.3	25.4	--	18.5	--
9	79.8	25.4/38.1	25.4/25.5	21.5	6.35X3.17
10	87.5	25.4/38.1/40.2	25.4/25.5	18.8	6.35X3.17
12	105.5	25.5/30.5/38.5/40.5	25.4/30.5/31.75/38.1 /45.5/47.5	35	8X8
17	152	--	114	25.4	4.5X3.5
18	157.8	38.5/40.5/60.5/63.5	25.4/30.5/31.75/38.1/46/47.5	35	8X8
20	175	38.1/40.2/60.2	25.4/31.75/38.1	35	6.35X3.17
20-Split	175	60.2	31.75	40	6.35X3.17
24	209.8	38.5/40.5	25.4/25.5/30.5/38.1/45.5/47.5	35	8X8