

HS-502A-127.5FB Technical Data Sheet

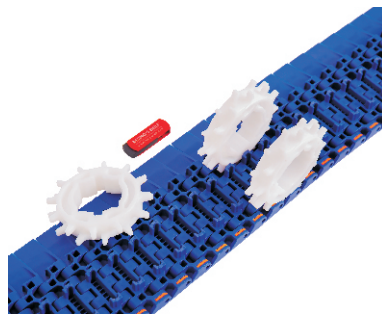
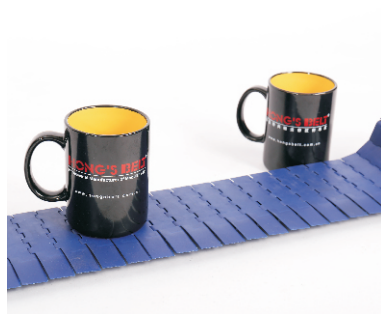
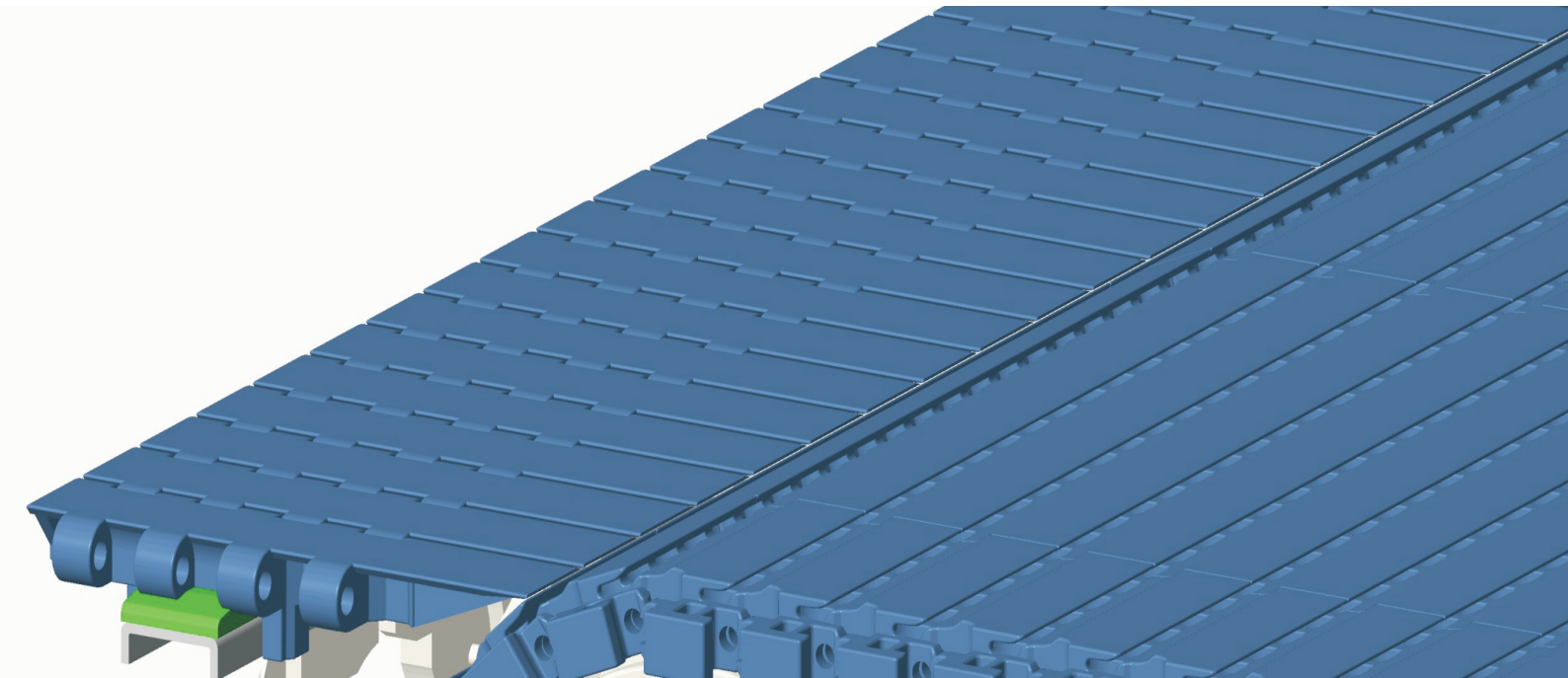
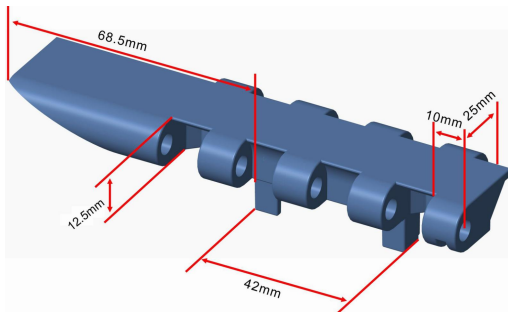

Pitch: 25mm Minimum Width: 127.5mm Open Area: 0% Approved: FDA Rod: Ø 4.9mm Flight: No Side Guard: No Curve: No	
--	--

Data

Belt Material	Belt Strength			Temperature		Belt Weight
	Straight		Curve	°C (min.)	°C (max.)	(Kg/M ²)
	Kg/M(BW)	N/M(BW)				
Polypropylene	1060	10600	--	1	100	7.1
Acetal	1720	17200	--	-40	80	11.0

BW – Belt Width

Color Table

Polypropylene					Polyethylene					Acetal					Nylon				
W	G	N	DB	B	W	G	N	DB	B	W	G	N	DB	B	W	G	N	DB	B
●	●									●				●					

W-White, G-Gray, N-Nature, DB-Dark brown, B-Blue (For more information of belt color, pls consult our sales team)

Friction Table

Belt Material	Friction Wear strips & Products							
	UHMW	HDPE	Steel	Glass	SUS	Plastic	Cardboard	Aluminum
Polypropylene	0.32	0.24	0.15	0.09	0.13	0.08	0.15	0.25
Polyethylene	0.13	0.11	0.26	0.19	0.31	0.16	0.21	0.41
Acetal	0.11	0.09	0.27	0.16	0.26	0.15	0.19	0.28
Nylon	0.18	0.13	0.25	0.16	0.26	0.16	0.19	0.27

SUS – Stainless Steel

Equivalent type with other Brand

Brand Name	Intralox	Habasit	UNI	Rexnord	MCC	ScanBelt
Series & Type	--	--	--	--	--	--

The above content is only for reference.

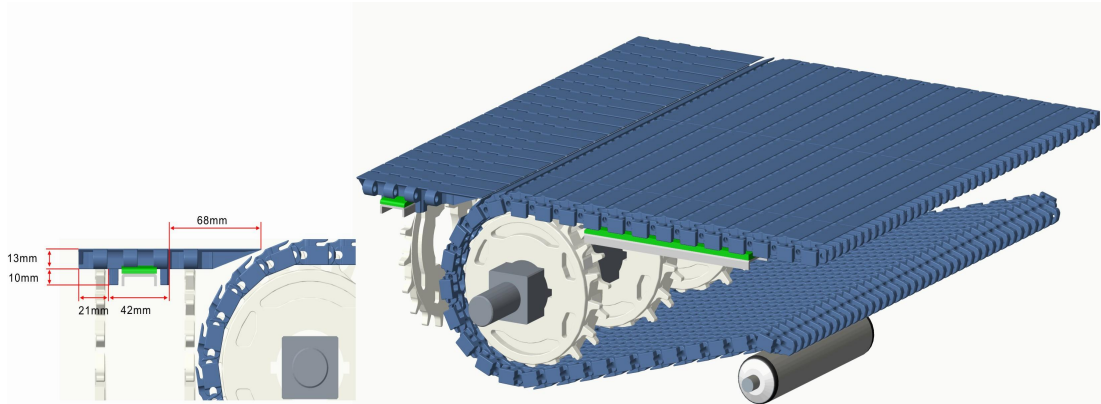

Conveyor Frame Dimensions

Unit : mm

No. Teeth	A (Min.)	B (Min.)	C (Max.)	D (Min.)	T
12	43.75	60	41.5	200	12.5
18	67.75	84	65.5	200	
24	93.75	110	91.5	250	

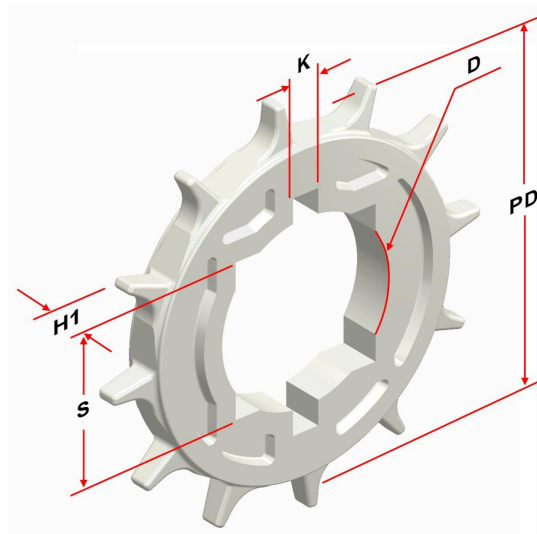

Sprocket Dimensions

Unit: mm

No. Teeth	PD	OD	S	D	H	K
12	96.59	100	25.4/38.1/39/40	25.4/28/30/31.75/35/40/46/47/50.8	11/18	--
18	143.97	148	25.4/38.1/40	25.4/30/31.75/35/36/40/45/47	18	--
24	191.53	200	38.1/40/50/60	--	30	--

Note: Thickness 11mm is only for 12T-S40.