

HS-4800A Technical Data Sheet

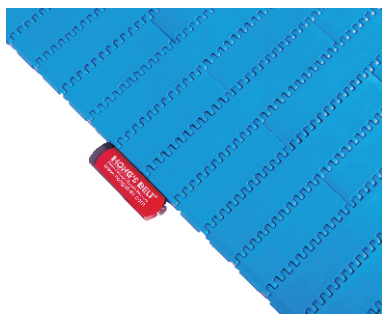
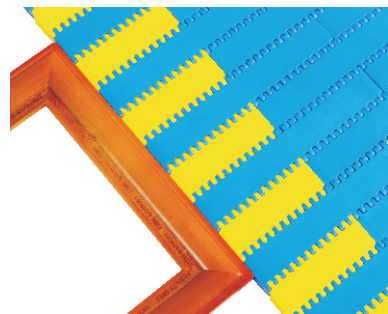

<p>Pitch: 25.4mm Minimum Width: 38mm Open Area: 0% Approved: FDA Rod: Ø 4.9mm Flight: No Side Guard: No Curve: No</p>	
--	--

Data

Belt Material	Belt Strength			Temperature		Belt Weight (Kg/M ²)
	Straight		Curve	°C (min.)	°C (max.)	
	Kg/M(BW)	N/M(BW)				
Polypropylene	2500	25000	--	1	100	8.4
Acetal	4000	40000	--	-40	80	10.4
HK	3600	36000	--	-40	80	9.9

BW – Belt Width

Color Table

Polypropylene					Polyethylene					Acetal					Nylon				
W	G	N	DB	B	W	G	N	DB	B	W	G	N	DB	B	W	G	N	DB	B
●	●			●						●	●			●					

W-White, G-Gray, N-Nature, DB-Dark brown, B-Blue (For more information of belt color, pls consult our sales team)

Friction Table

Belt Material	Friction Wear strips & Products							
	UHMW	HDPE	Steel	Glass	SUS	Plastic	Cardboard	Aluminum
Polypropylene	0.32	0.24	0.15	0.09	0.13	0.08	0.15	0.25
Polyethylene	0.13	0.11	0.26	0.19	0.31	0.16	0.21	0.41
Acetal	0.11	0.09	0.27	0.16	0.26	0.15	0.19	0.28
Nylon	0.18	0.13	0.25	0.16	0.26	0.16	0.19	0.27

SUS – Stainless Steel

Equivalent type with other Brand

Brand Name	Intralox	Habasit	UNI	Rexnord	MCC	ScanBelt
Series & Type	--	--	--	--	--	--

The above content is only for reference.

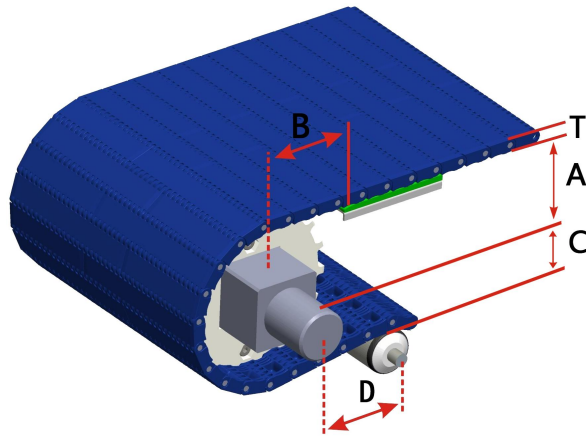

Conveyor Frame Dimensions

Unit : mm

No. Teeth	A (Min.)	B (Min.)	C (Max.)	D (Min.)	T
12	42.15	58.4	40	300	12.5
15	54.5	70.75	52.25	300	
19-Split	70.9	87.15	68.65	300	
24-Split	91	107.25	88.75	250	

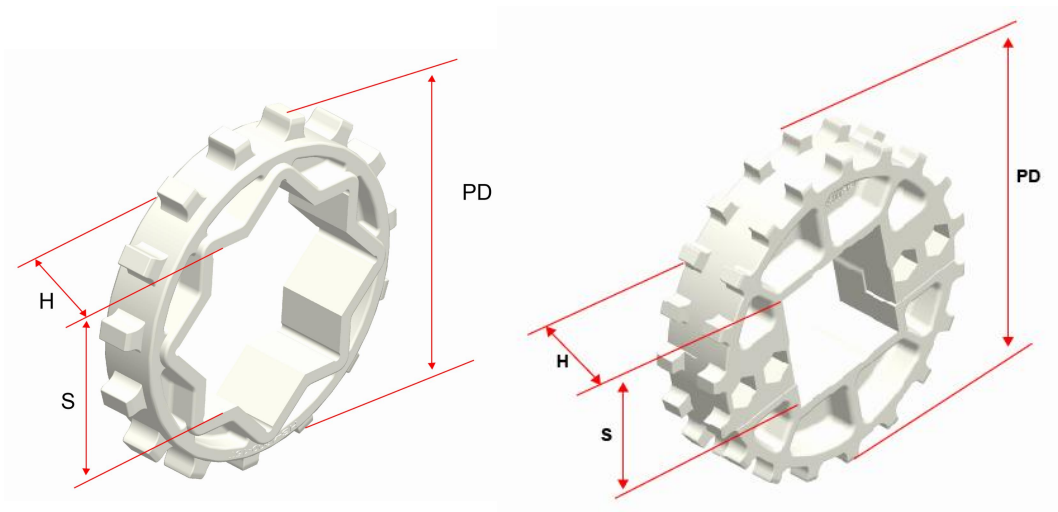

Sprocket Dimensions

Unit: mm

No. Teeth	PD	OD	S	D	H	K
12	98.14	96.79	38.1/40	25/40	18	8X8
15	122.17	121.5	38.1/40/60/63.5	--	25	--
19-Split	154.32	154.3	40/50/60	45	35	14X9
24-Split	194.60	194.5	60	--	35	--