

HS-3400ZS Technical Data Sheet

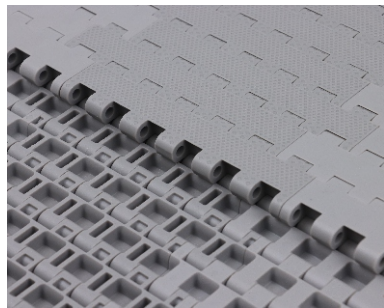
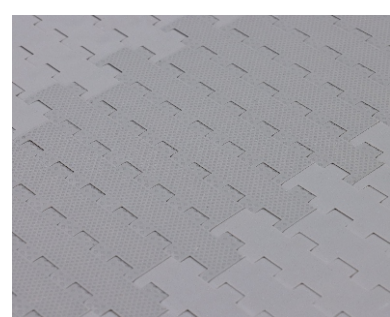
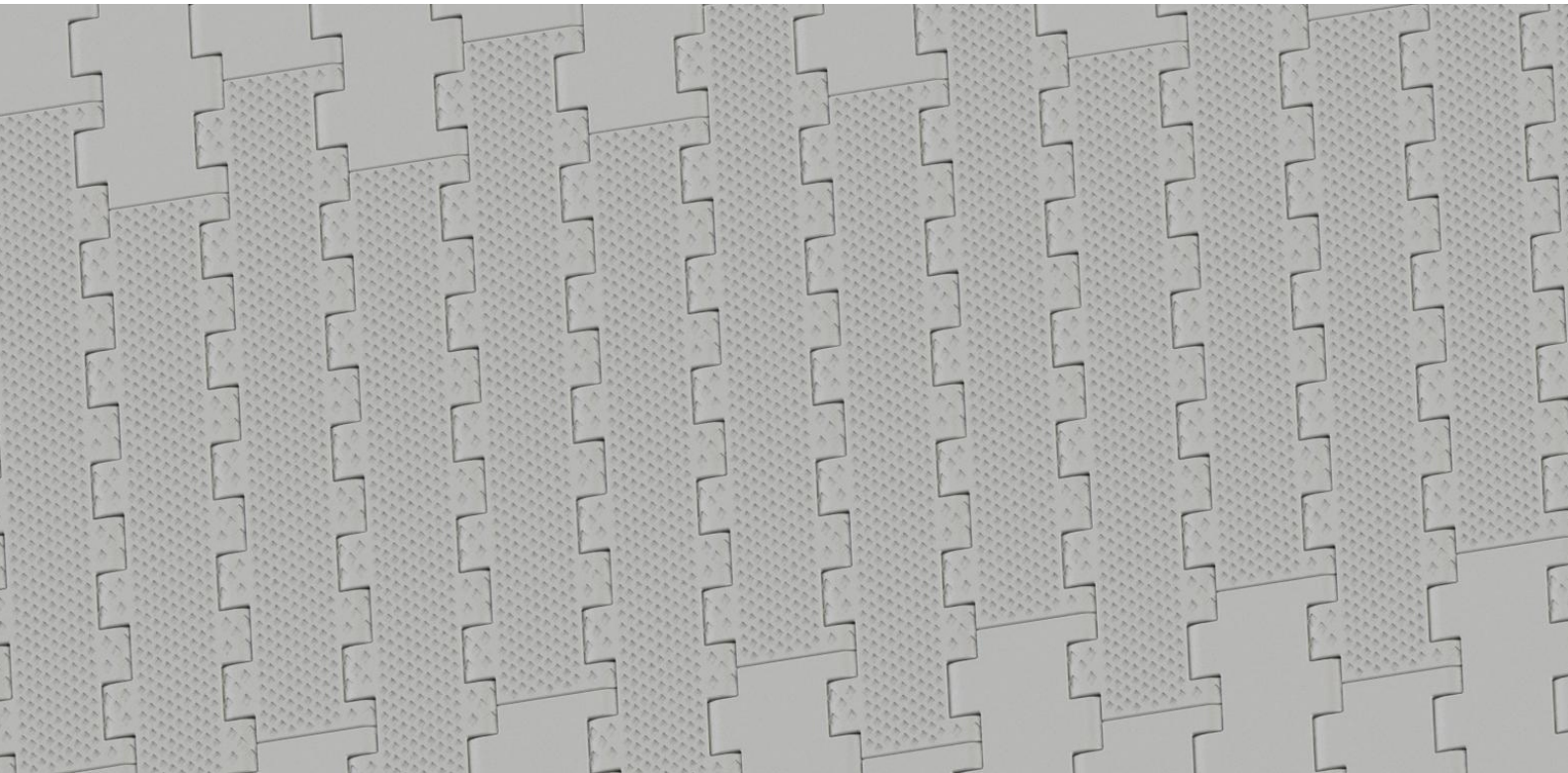

<p>Pitch: 25.4mm Minimum Width : 331mm Open Area : 0% Approved : FDA Rod : Ø 5.8mm Flight : No Side Guard : No Curve : No</p>	
--	--

Data

Belt Material	Belt Strength			Temperature		Belt Weight (Kg/M ²)
	Straight		Curve	°C (min.)	°C (max.)	
	Kg/M(BW)	N/M(BW)				
Polypropylene	2678	26780	--	1	100	8.5
Polyethylene	2600	26000	--	-60	60	9.2
Acetal	3720	37200	--	-40	80	12.5
Nylon	3520	35200	--	1	180	12.0

BW – Belt Width

Color Table

Polypropylene					Polyethylene					Acetal					Nylon				
W	G	N	DB	B	W	G	N	DB	B	W	G	N	DB	B	W	G	N	DB	B
●	●						●			●				●				●	

W-White, G-Gray, N-Nature, DB-Dark brown, B-Blue (For more information of belt color, pls consult our sales team)

Friction Table

Belt Material	Friction Wear strips & Products							
	UHMW	HDPE	Steel	Glass	SUS	Plastic	Cardboard	Aluminum
Polypropylene	0.32	0.24	0.15	0.09	0.13	0.08	0.15	0.25
Polyethylene	0.13	0.11	0.26	0.19	0.31	0.16	0.21	0.41
Acetal	0.11	0.09	0.27	0.16	0.26	0.15	0.19	0.28
Nylon	0.18	0.13	0.25	0.16	0.26	0.16	0.19	0.27

SUS – Stainless Steel

Equivalent type with other Brand

Brand Name	Intralox	Habasit	UNI	Rexnord	MCC	ScanBelt
Series & Type	S1400 Embedded Diamond Top	--	--	--	--	--

The above content is only for reference.

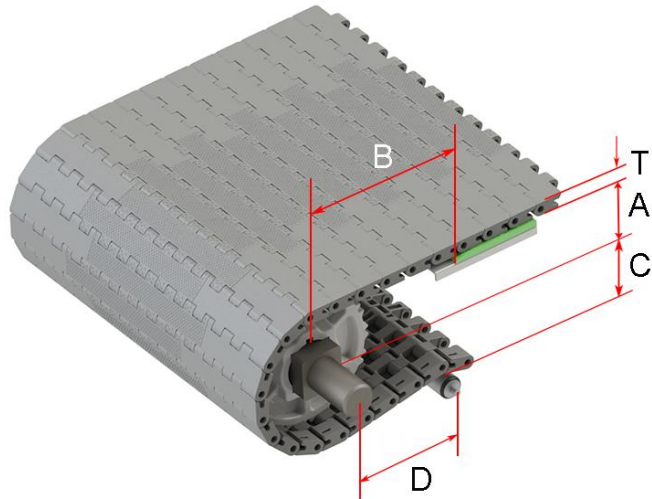

Conveyor Frame Dimensions

Unit : mm

No. Teeth	A (Min.)	B (Min.)	C (Max.)	D (Min.)	T
12	43.1	59.5	40.7	200	12.8
15	55.6	72	53.2	200	
16-Split	61.1	77.5	58.7	61.1	
18	68.1	84.5	65.7	200	
21-Split	80.6	97	78.2	200	
24	73.1	89.5	70.7	250	

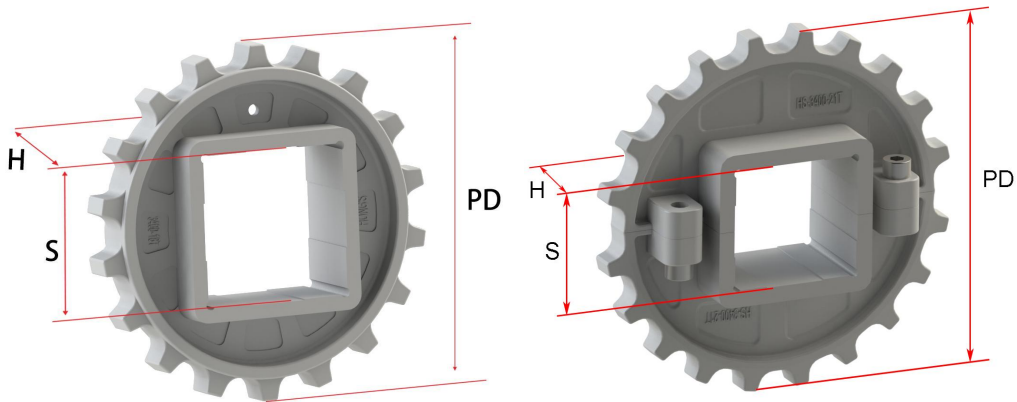

Sprocket Dimensions

Unit: mm

No. Teeth	PD	OD	S	D	H	K
12	98.14	99.3	38.1/40	--	37.6	--
15	122.17	124.25	38.1/40/60/63.5	--	38.1	--
16-Split	130.20	135	38.1/40	31.75	50	6.35X3.17
18	146.27	149.05	38.1/40/60	31.75/38.1	37.6	9.5X9.5
21-Split	170.42	174	38.1/40/60/63.5	--	50	--
24	194.60	158.73	40/60/63.5	36.6	30	9.6X9.6