

HS-3200A Technical Data Sheet

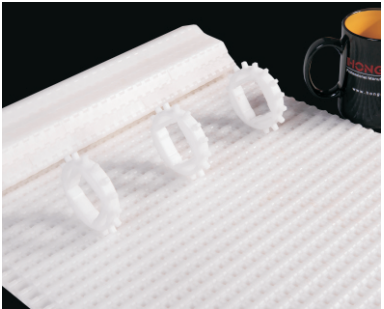
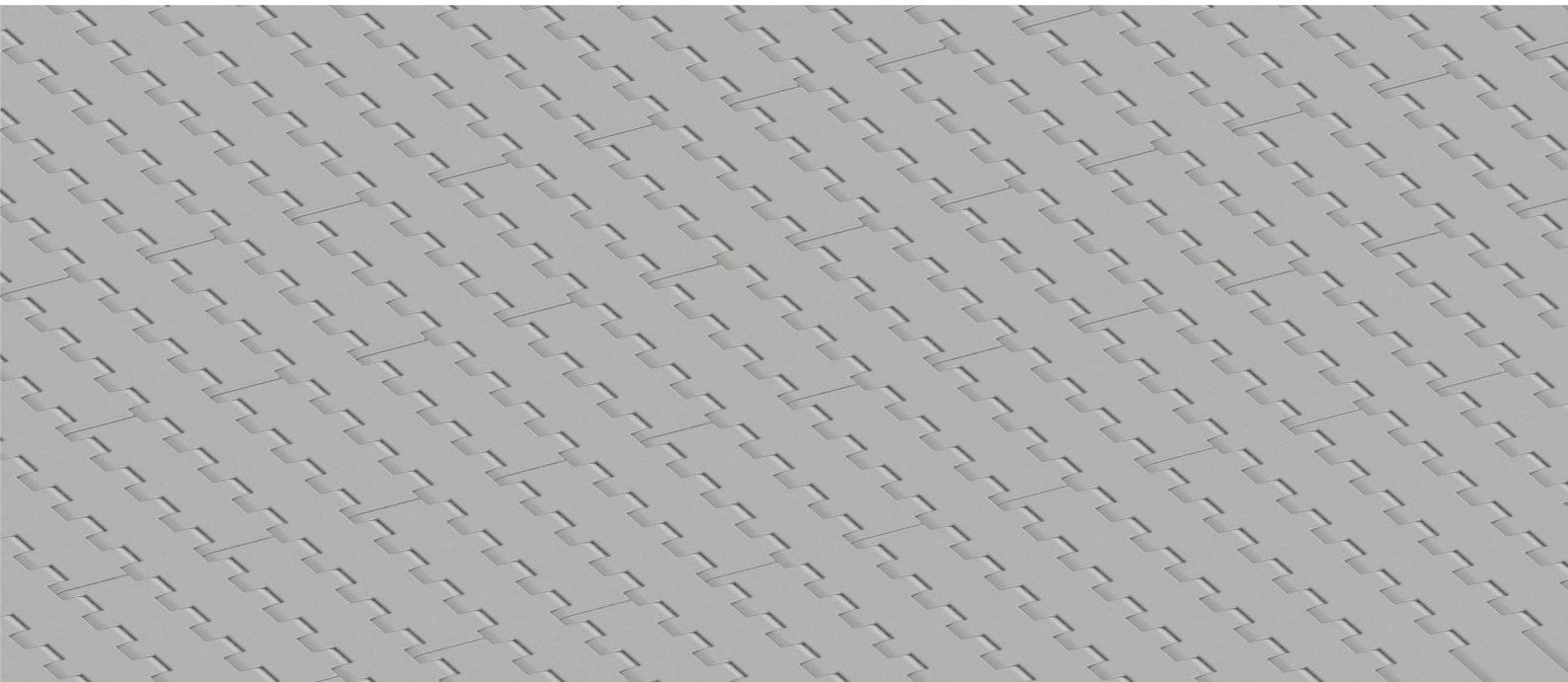

<p>Pitch: 15.2mm Minimum Width: 255mm Open Area: 0% Approved: FDA Rod: Ø 4.5mm Flight: No Side Guard: No Curve : No</p>	
--	--

Data

Belt Material	Belt Strength			Temperature		Belt Weight (Kg/M ²)
	Straight		Curve	°C (min.)	°C (max.)	
	Kg/M(BW)	N/M(BW)				
Polypropylene	1340	13400	--	1	100	5.22
Polyethylene	1280	12800	--	-60	60	5.42
Acetal	1770	17700	--	-40	80	7.57
Nylon	1520	15200	--	1	180	6.43

BW – Belt Width

Color Table

Polypropylene					Polyethylene					Acetal					Nylon				
W	G	N	DB	B	W	G	N	DB	B	W	G	N	DB	B	W	G	N	DB	B
●	●						●			●				●				●	

W-White, G-Gray, N-Nature, DB-Dark brown, B-Blue (For more information of belt color, pls consult our sales team)

Friction Table

Belt Material	Friction Wear strips & Products							
	UHMW	HDPE	Steel	Glass	SUS	Plastic	Cardboard	Aluminum
Polypropylene	0.32	0.24	0.15	0.09	0.13	0.08	0.15	0.25
Polyethylene	0.13	0.11	0.26	0.19	0.31	0.16	0.21	0.41
Acetal	0.11	0.09	0.27	0.16	0.26	0.15	0.19	0.28
Nylon	0.18	0.13	0.25	0.16	0.26	0.16	0.19	0.27

SUS – Stainless Steel

Equivalent type with other Brand

Brand Name	Intralox	Habasit	UNI	Rexnord	MCC	ScanBelt
Series & Type	S1000 Flat Top	--	--	--	--	--

The above content is only for reference.

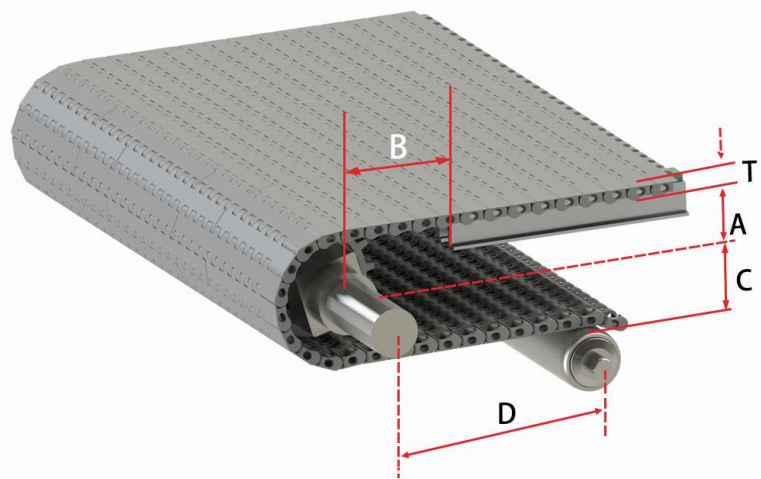

Conveyor Frame Dimensions

Unit : mm

No. Teeth	A (Min.)	B (Min.)	C (Max.)	D (Min.)	T
16	36.1	50.5	35.7	200	8.8
24 / 24-Split	56.8	71.2	56.4	200	
32	76.3	90.7	75.9	200	

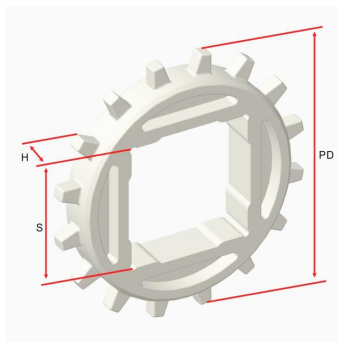

16T

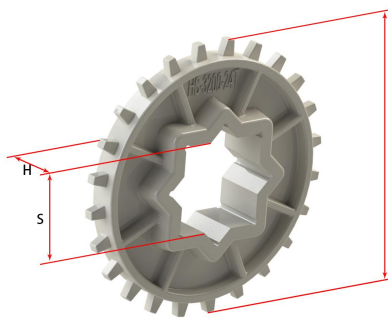

24T, 32T

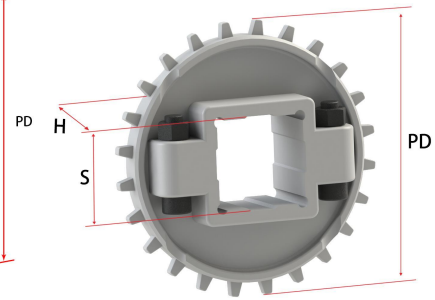

24T-Split

Sprocket Dimensions

Unit: mm

No. Teeth	PD	OD	S	D	H	K
16	77.91	81	38.1/40	--	12.7	--
24	116.45	122.4	38.1/40/60	25.4/30/38.1	24.5	6.35X3.17
24-Split	116.45	121	38.1/40	--	38	--
32	155.08	161.4	38.1/40	25.4	24.5	6.35X3.17