

## HS-2600B Technical Data Sheet

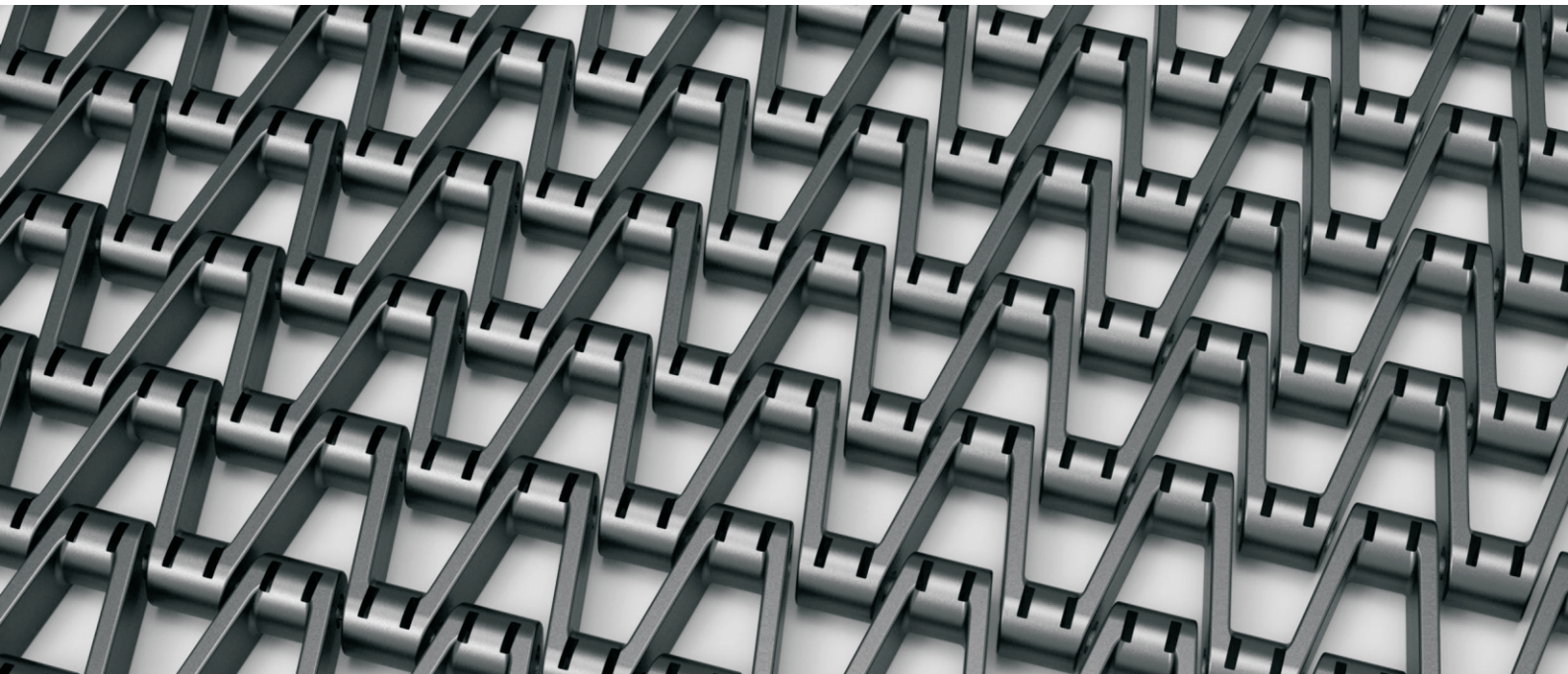

<p>Pitch: 25mm                  Minimum Width: 182mm                  Open Area: 44%                  Approved: FDA                  Rod: Ø 4.5mm                  Flight: No                  Side Guard: No                  Curve: No</p>	
--	--

### Data

Belt Material	Belt Strength			Temperature		Belt Weight (Kg/M <sup>2</sup> )
	Straight		Curve	°C (min.)	°C (max.)	
	Kg/M(BW)	N/M(BW)				
Polypropylene	1100	11000	--	1	100	4.8
Polyethylene	1000	10000	--	-60	60	5.1
Acetal	1580	15800	--	-40	80	9.2
Nylon	1350	13500	--	1	260	6.8

BW – Belt Width

### Color Table

Polypropylene					Polyethylene					Acetal					Nylon				
W	G	N	DB	B	W	G	N	DB	B	W	G	N	DB	B	W	G	N	DB	B
●	●						●			●				●				●	

W-White, G-Gray, N-Nature, DB-Dark brown, B-Blue (For more information of belt color, pls consult our sales team)

### Friction Table

Belt Material	Friction Wear strips & Products							
	UHMW	HDPE	Steel	Glass	SUS	Plastic	Cardboard	Aluminum
Polypropylene	0.32	0.24	0.15	0.09	0.13	0.08	0.15	0.25
Polyethylene	0.13	0.11	0.26	0.19	0.31	0.16	0.21	0.41
Acetal	0.11	0.09	0.27	0.16	0.26	0.15	0.19	0.28
Nylon	0.18	0.13	0.25	0.16	0.26	0.16	0.19	0.27

SUS – Stainless Steel

### Equivalent type with other Brand

Brand Name	Intralox	Habasit	UNI	Rexnord	MCC	ScanBelt
Series & Type	--	--	--	--	--	--

The above content is only for reference.

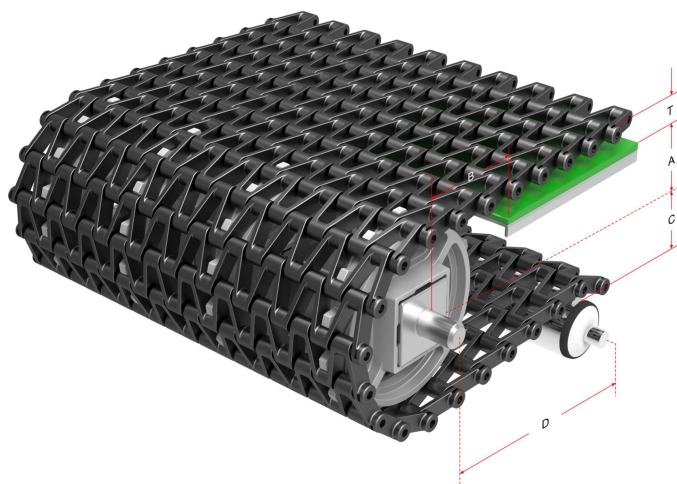

## Conveyor Frame Dimensions

Unit : mm

No. Teeth	A ( Min.)	B ( Min.)	C ( Max.)	D ( Min.)	T
9	31	46.5	29.5	250	11
11	39	54.5	37.5	250	
13	46.5	62	45	250	
15	54.5	70	53	250	

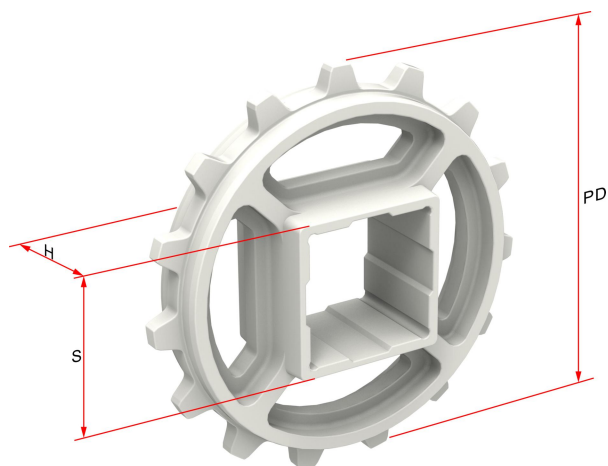

## Sprocket Dimensions

Unit: mm

No. Teeth	PD	OD	S	D	H	K
9	73.10	73	30	25.4	35	6.35X3.17
11	88.74	89	38.1/40	25.4/30	35	8X8
13	104.46	104	38.1/40	25.4/30	35	8X8
15	120.24	120	38.1/40	25.4/40	35	6.35X3.17