

HS-200A Technical Data Sheet

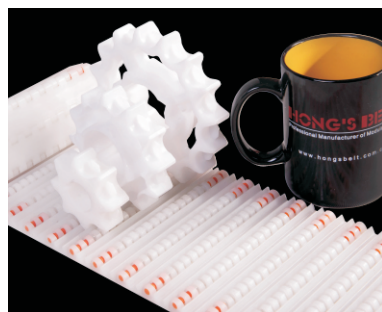
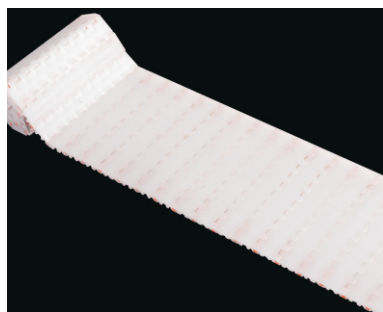
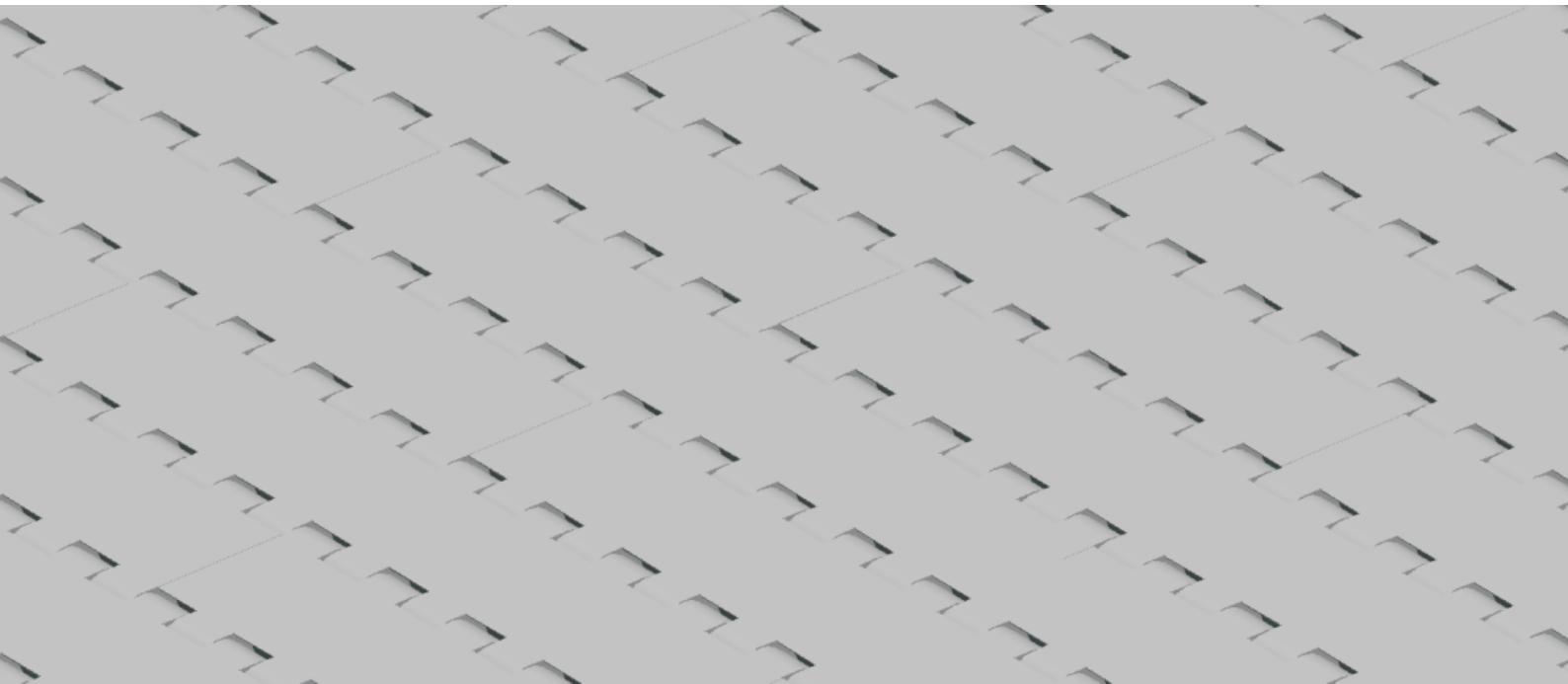

<p>Pitch: 25.4mm Minimum Width: 45mm Open Area: 0% Approved: FDA Rod: Ø 4.9mm Flight: Yes Side Guard: Yes Curve: No</p>	
--	--

Data

Belt Material	Belt Strength			Temperature		Belt Weight (Kg/M ²)
	Straight		Curve	°C (min.)	°C (max.)	
	Kg/M(BW)	N/M(BW)				
Polypropylene	1155	11550	--	1	100	5.2
Polyethylene	1105	11050	--	-60	60	5.4
Acetal	1520	15200	--	-40	80	7.6
Nylon	1310	13100	--	1	180	6.6

BW – Belt Width

Color Table

Polypropylene					Polyethylene					Acetal					Nylon				
W	G	N	DB	B	W	G	N	DB	B	W	G	N	DB	B	W	G	N	DB	B
●	●						●			●	●					●			

W-White, G-Gray, N-Nature, DB-Dark brown, B-Blue (For more information of belt color, pls consult our sales team)

Friction Table

Belt Material	Friction Wear strips & Products							
	UHMW	HDPE	Steel	Glass	SUS	Plastic	Cardboard	Aluminum
Polypropylene	0.32	0.24	0.15	0.09	0.13	0.08	0.15	0.25
Polyethylene	0.13	0.11	0.26	0.19	0.31	0.16	0.21	0.41
Acetal	0.11	0.09	0.27	0.16	0.26	0.15	0.19	0.28
Nylon	0.18	0.13	0.25	0.16	0.26	0.16	0.19	0.27

SUS – Stainless Steel

Equivalent type with other Brand

Brand Name	Intralox	Habasit	UNI	Rexnord	MCC	ScanBelt
Series & Type	--	--	--	--	--	--

The above content is only for reference.

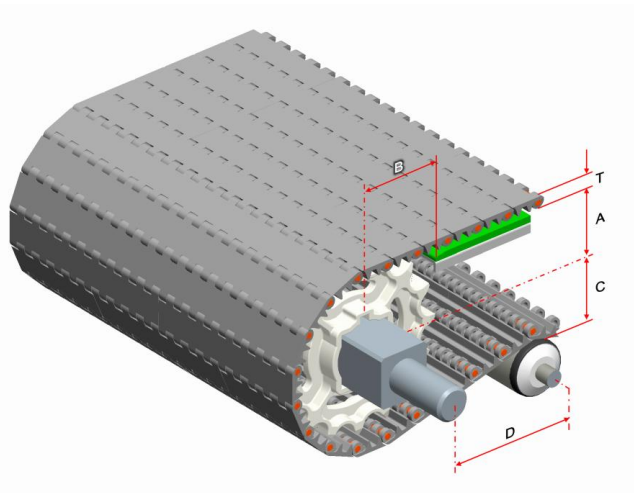

Conveyor Frame Dimensions

Unit : mm

No. Teeth	A (Min.)	B (Min.)	C (Max.)	D (Min.)	T
7	23.5	38.5	22.5	200	10
8	28.4	43.4	27.4	200	
10	36.3	51.3	35.3	200	
12	44.3	59.3	43.3	200	
16	61	76	60	200	
20	77.5	92.5	76.5	200	

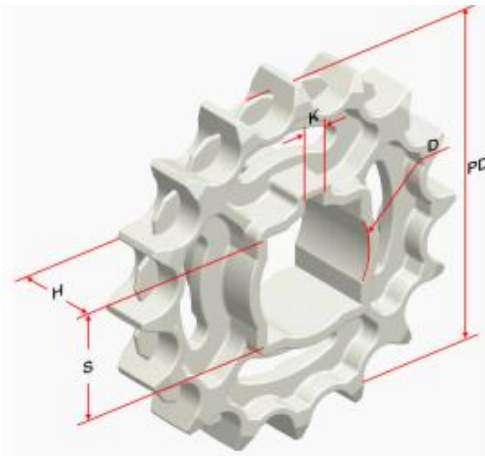

Sprocket Dimensions

Unit: mm

No. Teeth	PD	OD	S	D	H	K
7	58.54	57	25	--	22	--
8	66.37	66.8	25.4	25.4/30	22	6X6
10	82.20	82.6	38.1/40	20/25.4/30/45	22	8X8
12	98.14	98.7	35/38.1/40	20/25.4/30/40/45	38	8X8
16	130.20	132	35/38.1/40	25.4/30/35/45	38	8X8
20	162.37	165	38.1/40	25/47	38	8X8