

## HS-2000A-RC Technical Data Sheet

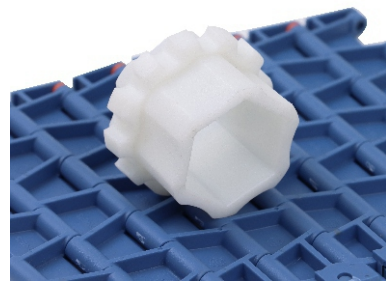
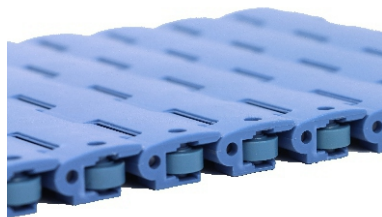
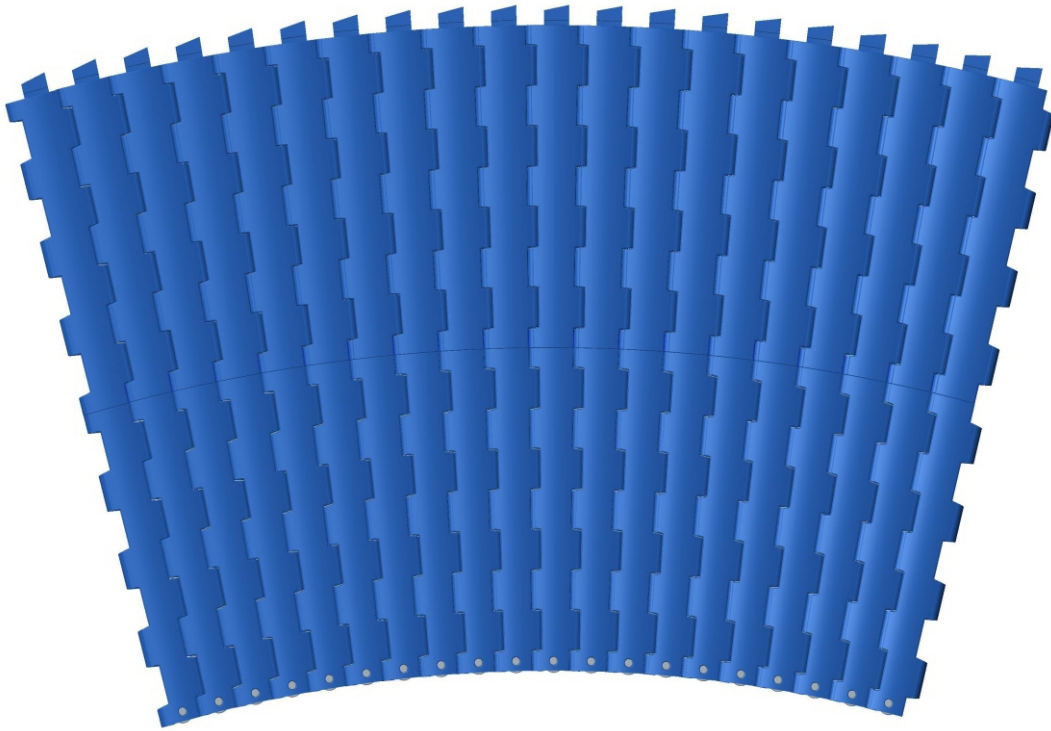
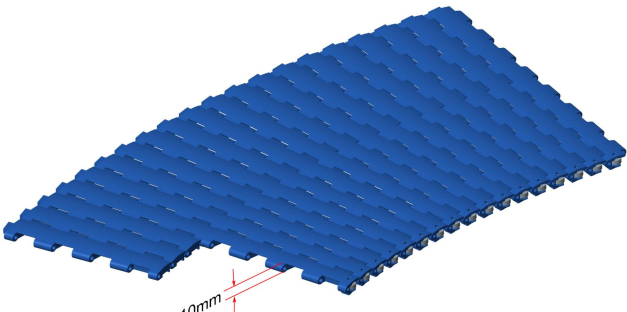

<p>Minimum Radius: 1000mm                  Minimum Width: 200mm                  Open Area: 0%                  Approved: FDA                  Rod: Ø 4.9mm                  Flight: No                  Side Guard: No                  Curve: Yes</p>	
---	--

## Data

Belt Material	Belt Strength		Temperature		Belt Weight (Kg/M <sup>2</sup> )
	Straight		°C (min.)	°C (max.)	
	Kg/M(BW)	N/M(BW)			
Polypropylene	1600	16000	1	100	4.63
Polyethylene	1550	15500	-60	60	4.74
Acetal	2640	26400	-40	80	6.51
Nylon	2230	22300	1	180	5.76

BW – Belt Width

## Color Table

Polypropylene					Polyethylene					Acetal					Nylon				
W	G	N	DB	B	W	G	N	DB	B	W	G	N	DB	B	W	G	N	DB	B
	●			●			●				●			●				●	

W-White, G-Gray, N-Nature, DB-Dark brown, B-Blue (For more information of belt color, pls consult our sales team)

## Friction Table

Belt Material	Friction Wear strips & Products							
	UHMW	HDPE	Steel	Glass	SUS	Plastic	Cardboard	Aluminum
Polypropylene	0.32	0.24	0.15	0.09	0.13	0.08	0.15	0.25
Polyethylene	0.13	0.11	0.26	0.19	0.31	0.16	0.21	0.41
Acetal	0.11	0.09	0.27	0.16	0.26	0.15	0.19	0.28
Nylon	0.18	0.13	0.25	0.16	0.26	0.16	0.19	0.27

SUS – Stainless Steel

## Equivalent type with other Brand

Brand Name	Intralox	Habasit	UNI	Rexnord	MCC	ScanBelt
Series & Type	--	--	--	--	--	--

The above content is only for reference.

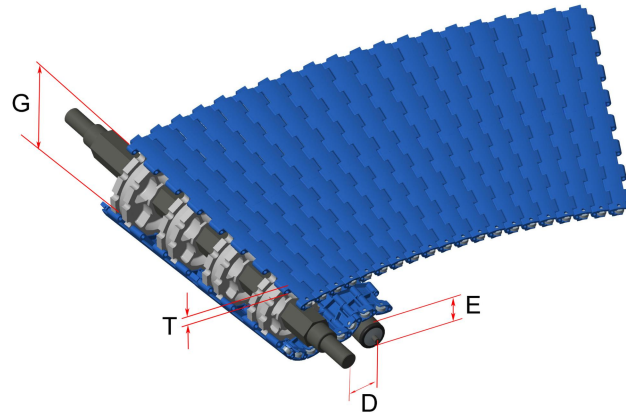

## Conveyor Frame Dimensions

Unit : mm

No. Teeth	D ( Min.)	E ( Min.)	G	T
12	200	40	5.6°	10

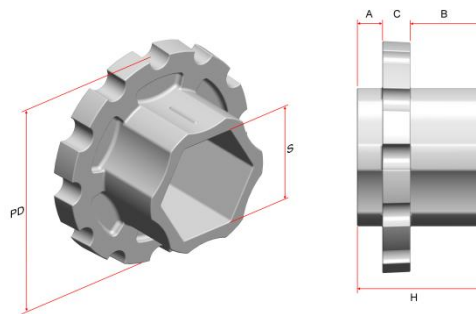

## Sprocket Dimensions

Unit: mm

Belt Width	Sprocket No.	PD	OD	S	A	B	C	H
200	1	67	65	41.5	35	0	11	46
	2	76.1	72.9		10	29		50
400	3	85.3	82.4		10	29		
	4	94.4	92.4		10	29		
600	5	103.5	101.9		10	29		
	6	112.7	111.4		10	29		
800	7	121.8	121.4		10	29		
	8	131	130.1		10	29		
1000	9	140.1	140.4		10	29		
	10	149.3	150.4		10	29		
1200	11	158.4	159.4		10	29		
	12	168.5	168.9		10	29		
1400	13	178.5	178.9		10	29		
	14	188	188.4		10	29		

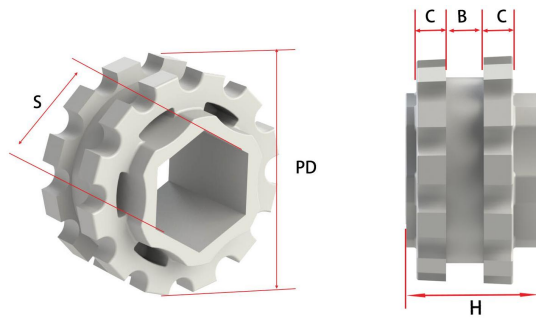

## Sprocket Dimensions

Unit: mm

Belt Width	Sprocket No.	PD	OD	S	B	C	H
200	1-2R	65.5	69	41.5	14	11	71
	2-2R	72.7	76		50		
400	3-2R	82.4	85.3		14		50
	4-2R	92	94.6		14		50
600	5-2R	101.7	104.1		14		50
	6-2R	111.4	113.4		14		50
800	7-2R	121	122.7		14		50
	8-2R	130.7	132.1		14		50
1000	9-2R	140.3	141.4		14		50
	10-2R	150	150.7		14		50
1200	11-2R	159.7	160.1		14		50
	12-2R	169.3	169.4		14		50
1400	13-2R	178.9	178.6		14		50
	14-2R	188.7	188.1		14		50

## Installation of sprockets

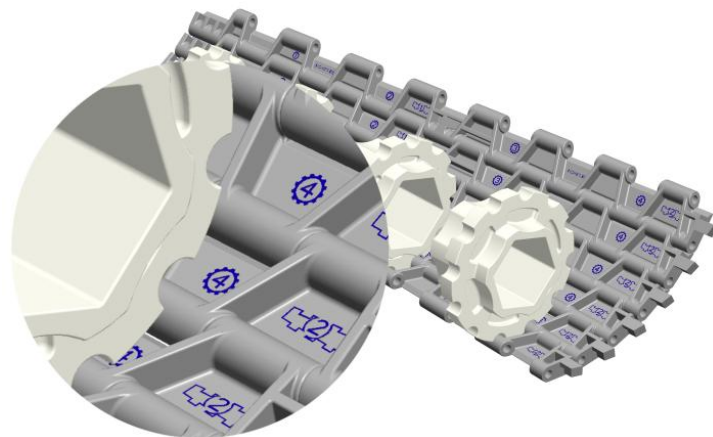

Please install the sprockets according to the graphical representation.

## HS-2000A-RC Flat Top Radius Modular Conveyor Belt

HS-2000A-RC Flat Top Radius Modular Conveyor Belt is developed specially for logistics transportation by HONG'S BELT. The minimum inside turning radius of HS-2000A-RC is 1000mm, it doesn't change with the width. Width of HS-2000A-RC ranges from 200mm to 1400mm (200mm, 300mm, 400mm, 500mm, 600mm, 700mm, 800mm, 900mm, 1000mm, 1100mm, 1200mm, 1300mm, 1400mm). Max width is 1400mm, which can meet the wide range of requirements of logistics transportation.

### Driving Mode of HS-2000A-RC

For turning conveyors installed with traditional PVC conveyor belt, the belt is fixed with unstable bearing parts, so the life time of it is very short and the structure of the conveying machine is large; At the same time, the belt is driven by smooth roller, so it is easy to slip, which causes the low tension force and usually affects the production.

HS-2000A-RC Flat Top Radius Modular Conveyor Belt is designed with module structure, and is driven by sprockets, which solves the slip of belt and ensure the belt in most stable condition in operation.

The bore of HS-2000A-RC sprocket is 41.5mm hexagon, it can be matched with 41mm standard hexagonal shaft, so it is easy to get and process the raw material, more importantly, this design solves the chordal action of quadrilateral shaft and brings more stable operation.

### Advantages of HS-2000A-RC

HS-2000A-RC Flat Top Radius Modular Conveyor Belt is stable in operation, and because of its fixed structure design, straight sections are not need in driving end, which save the manufacturing cost and the space of conveying system.

HS-2000A-RC Flat Top Radius Modular Conveyor Belt is made from Acetal, it can endure instant impact with low friction coefficient and high impact resistance, tensile strength of it is 10 times stronger than common radius PVC Conveyor belt.

HS-2000A-RC Flat Top Radius Modular Conveyor Belt is drive by sprockets, and can endure instant high-speed and big load capacity. It is widely used in Paper, Printing, Beverage, packaging industry etc. both for light-duty and heavy-duty conveying.

### Guide Rail & Wear Strips

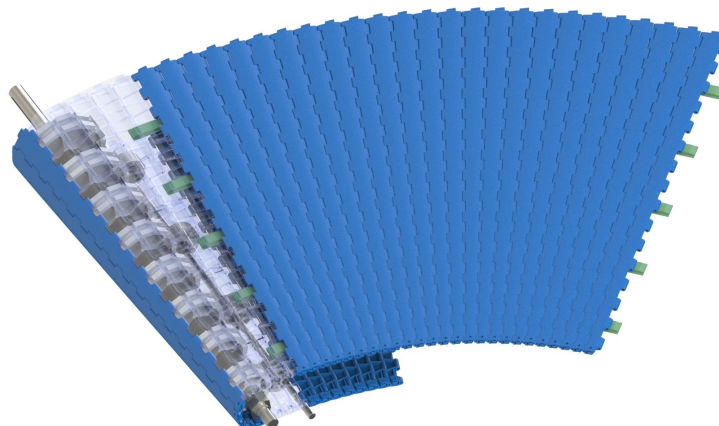

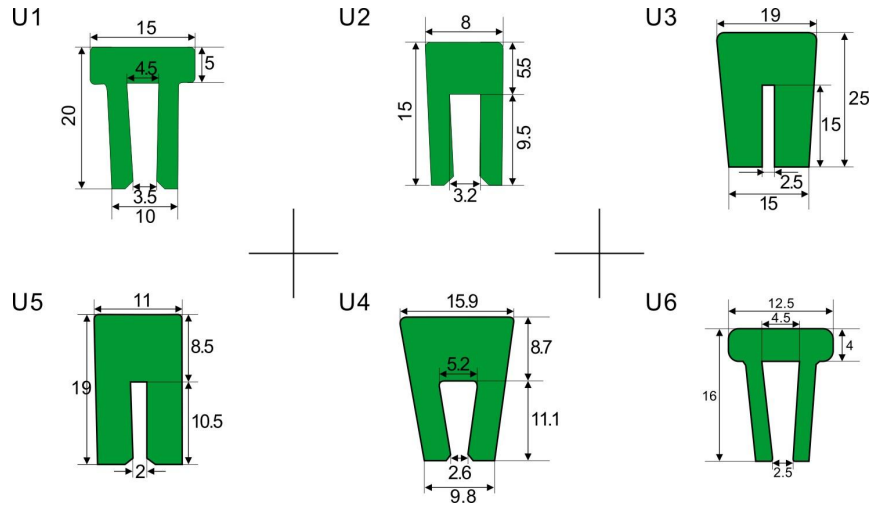

- We have different kinds of guide rail and wear strips for your choice; for more information, please consult our sales team.

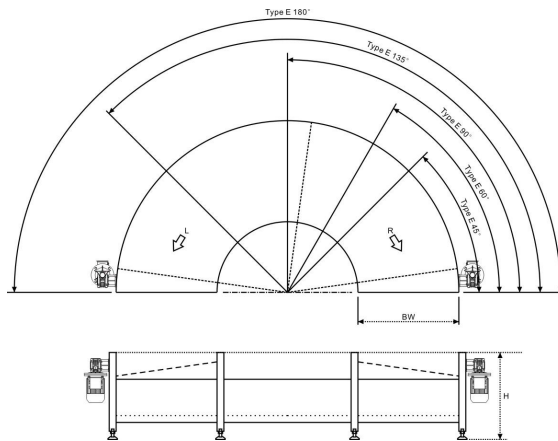

BW : 200mm 300mm 400mm 500mm 600mm 700mm 800mm 900mm 1000mm 1100mm 1200mm 1300mm 1400mm