

HS-1701 SERIES



Materials



Sprockets



Applications

Plate Materials: POM-DP, POM-LF

Pin Material: Cold rolled austenitic stainless steel

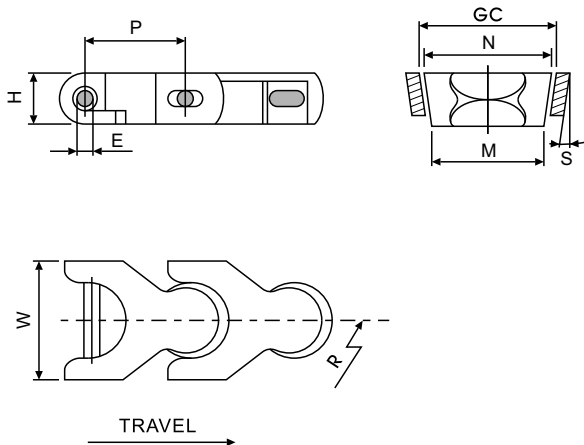

Dimension	mm	inches
P	50.0	1.969
R	150.0	5.906
W	52.0	2.047
H	25.0	0.984
N	58.4	2.300
S	8.0	0.315
E	8.0	0.315
M	52.4	2.063
GC	62.0	2.441

HS-1701 (Side Flexing Keel Chains)

CHARACTERISTICS

	Width W		Working Load		Radius		Reverse Radius		Weight (kg/m)
	(mm)	(inch)	N(21°C)	lbs(21°C)	(mm)	(inch)	(mm)	(inch)	
HS-1701	52.0	2.05	2669	600	150	5.90	50	1.97	1.42