

HS-1700B Technical Data Sheet

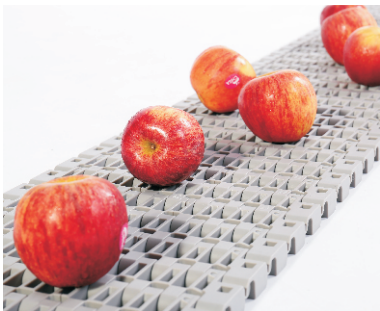
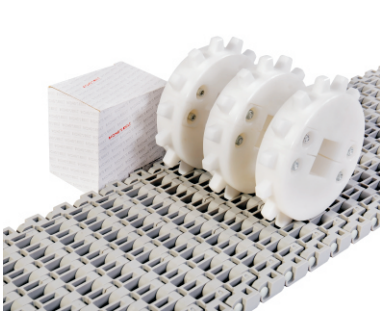
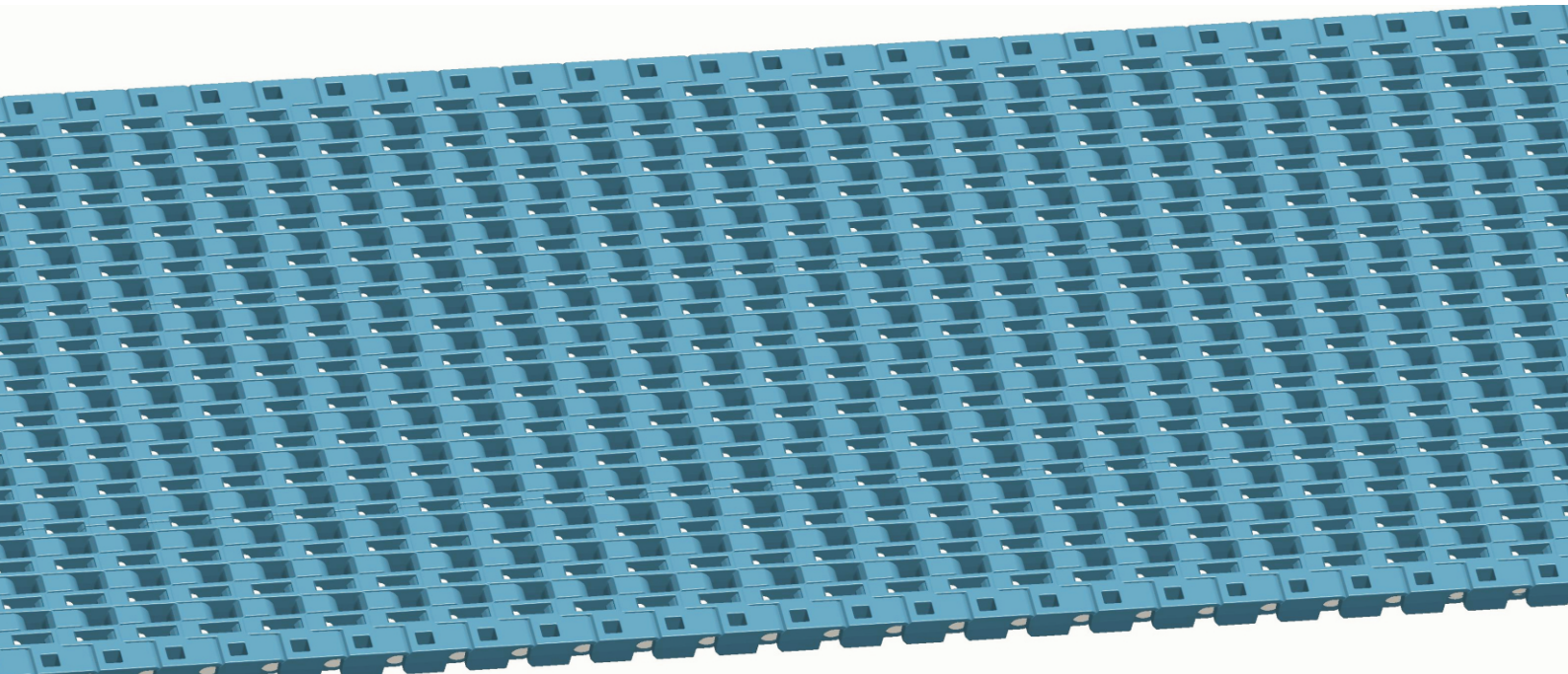

<p>Pitch: 38.1mm Minimum Width: 250mm Open Area: 37% Approved: FDA Rod: Ø 8.0mm Flight: Yes Side Guard: No Curve: No</p>	
---	--

Data

Belt Material	Belt Strength			Temperature		Belt Weight (Kg/M ²)
	Straight		Curve	°C (min.)	°C (max.)	
	Kg/M(BW)	N/M(BW)				
PP+AS	3000	30000	--	1	104	15.0
Acetal	5000	50000	--	-40	80	21.3
Acetal+AS	5000	50000	--	-40	90	21.3

BW – Belt Width AS - Anti-Static

Color Table

Polypropylene					Polyethylene					Acetal					Nylon									
W	G	N	DB	B	W	G	N	DB	B	W	G	N	DB	B	W	G	N	DB	B					
●	●									●														

W-White, G-Gray, N-Nature, DB-Dark brown, B-Blue (For more information of belt color, pls consult our sales team)

Friction Table

Belt Material	Friction Wear strips & Products							
	UHMW	HDPE	Steel	Glass	SUS	Plastic	Cardboard	Aluminum
Polypropylene	0.32	0.24	0.15	0.09	0.13	0.08	0.15	0.25
Polyethylene	0.13	0.11	0.26	0.19	0.31	0.16	0.21	0.41
Acetal	0.11	0.09	0.27	0.16	0.26	0.15	0.19	0.28
Nylon	0.18	0.13	0.25	0.16	0.26	0.16	0.19	0.27

SUS – Stainless Steel

Equivalent type with other Brand

Brand Name	Intralox	Habasit	UNI	Rexnord	MCC	ScanBelt
Series & Type	S1700 Flush Grid	--	--	--	--	--

The above content is only for reference.

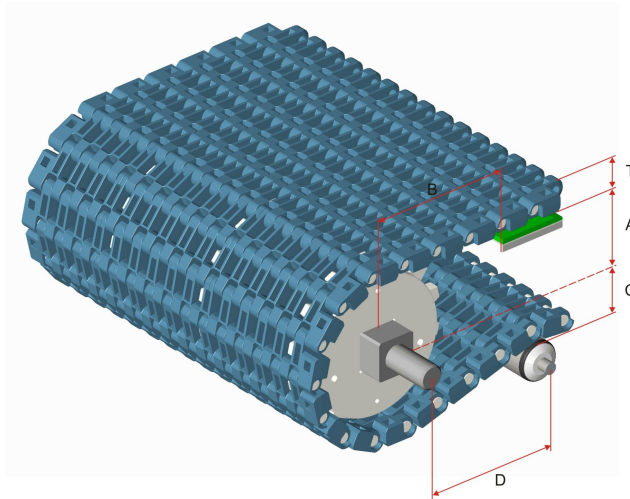

Conveyor Frame Dimensions

Unit : mm

No. Teeth	A (Min.)	B (Min.)	C (Max.)	D (Min.)	T
14-Split	78.8	98.25	73.35	300	18.9
16-Split	91.64	111.1	86.19	300	
22-Split	128.3	147.75	122.85	300	

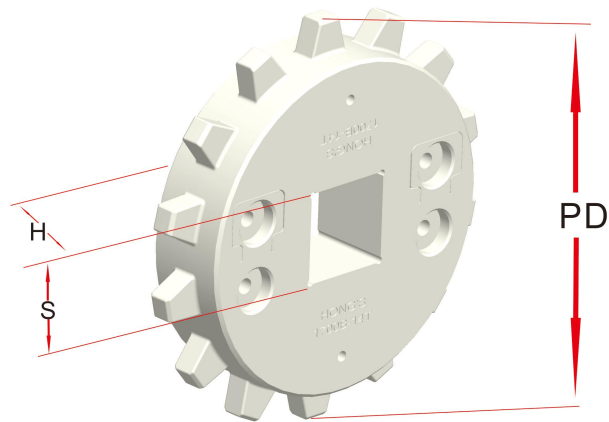

Sprocket Dimensions

Unit: mm

No. Teeth	PD	OD	S	D	H	K
14-Split	171.22	176.5	40/60	--	38	--
16-Split	195.29	202.17	40/60	--	38	--
22-Split	267.72	275.5	60	--	38	--

- The above sprockets are standard, and it also can be customized according to customer's request, including the teeth number of sprocket and the size of square bore; the processing time is about 1 week.