

## HS-1500B Technical Data Sheet

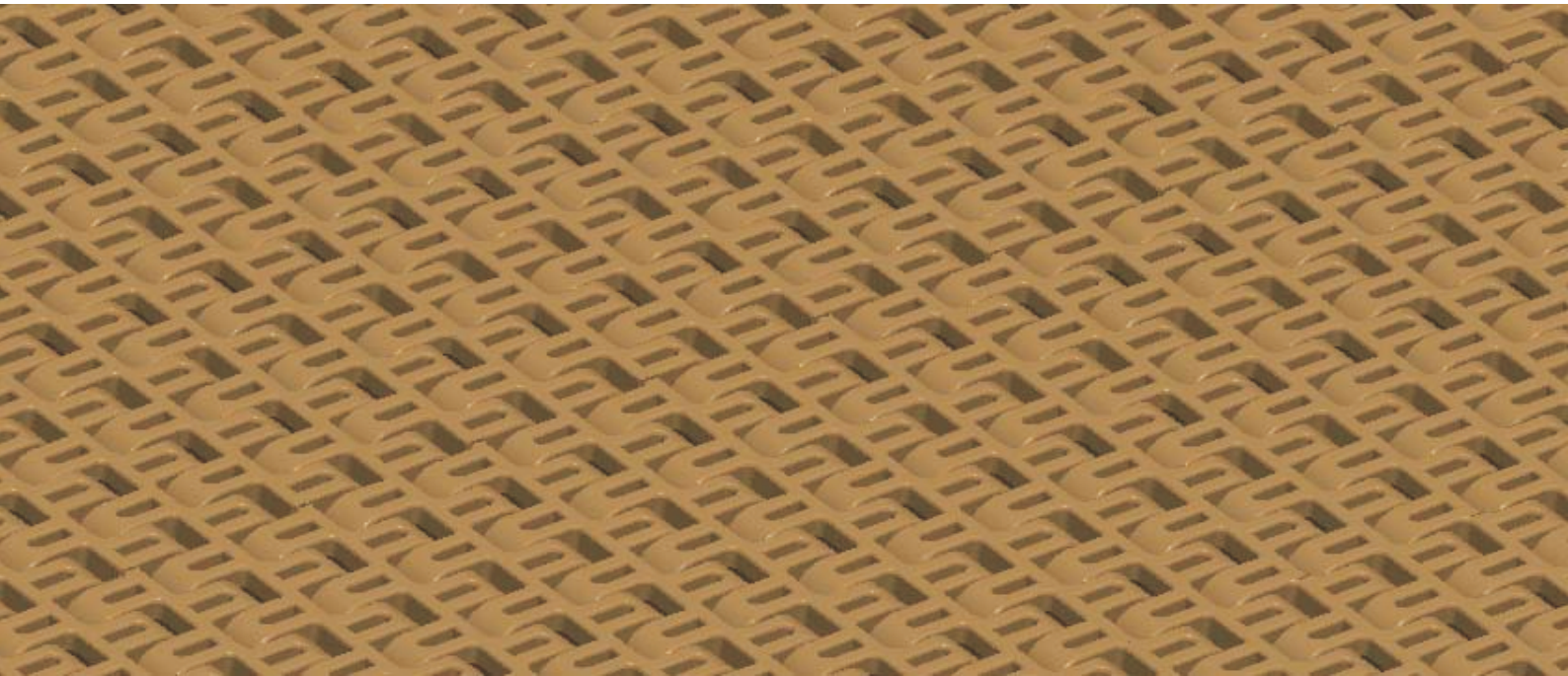

Pitch : 12.7mm Minimum Width : 107mm Open Area : 19% Approved : FDA Rod : Ø 4.7mm Flight : No Side Guard : No Curve : No	
---	--

## Data

Belt Material	Belt Strength			Temperature		Belt Weight (Kg/M <sup>2</sup> )
	Straight		Curve	°C (min.)	°C (max.)	
	Kg/M(BW)	N/M(BW)				
Polypropylene	1020	10200	--	1	100	5.4
Polyethylene	860	8600	--	-60	60	5.6
Acetal	1650	16500	--	-40	80	7.6
Nylon	1520	15200	--	1	180	6.8

BW – Belt Width

## Color Table

Polypropylene					Polyethylene					Acetal					Nylon				
W	G	N	DB	B	W	G	N	DB	B	W	G	N	DB	B	W	G	N	DB	B
●	●						●			●			●	●				●	

W-White, G-Gray, N-Nature, DB-Dark brown, B-Blue (For more information of belt color, pls consult our sales team)

## Friction Table

Belt Material	Friction Wear strips & Products							
	UHMW	HDPE	Steel	Glass	SUS	Plastic	Cardboard	Aluminum
Polypropylene	0.32	0.24	0.15	0.09	0.13	0.08	0.15	0.25
Polyethylene	0.13	0.11	0.26	0.19	0.31	0.16	0.21	0.41
Acetal	0.11	0.09	0.27	0.16	0.26	0.15	0.19	0.28
Nylon	0.18	0.13	0.25	0.16	0.26	0.16	0.19	0.27

SUS – Stainless Steel

## Equivalent type with other Brand

Brand Name	Intralox	Habasit	UNI	Rexnord	MCC	ScanBelt
Series & Type	--	--	--	--	--	--

The above content is only for reference.

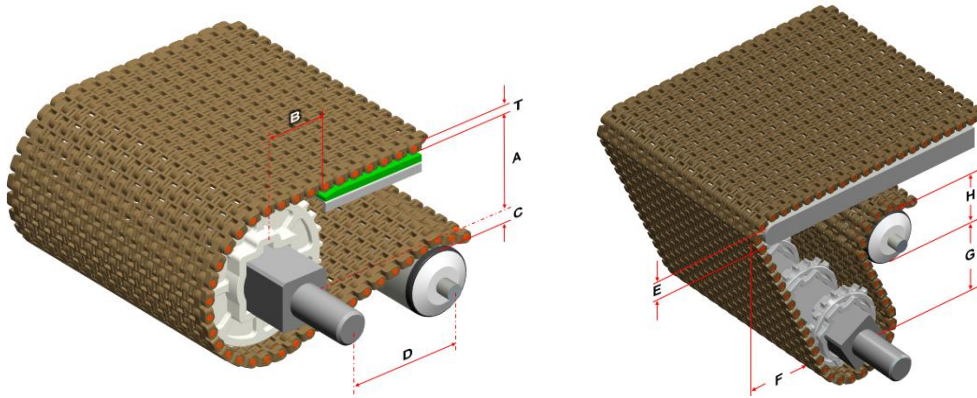

## Conveyor Frame Dimensions

Unit : mm

No. Teeth	A ( Min.)	B ( Min.)	C ( Max.)	D ( Min.)	E ( Min.)	H( Min.)	T
10	16.25	30.5	16	100	Ø 20	Ø 60	8.5
15	27.25	41.5	27	100	Ø 20	Ø 60	
19	34.75	49	34.5	100	Ø 20	Ø 60	
24	46	60.25	45.75	130	Ø 20	Ø 60	
28	53.25	67.5	53	130	Ø 20	Ø 60	

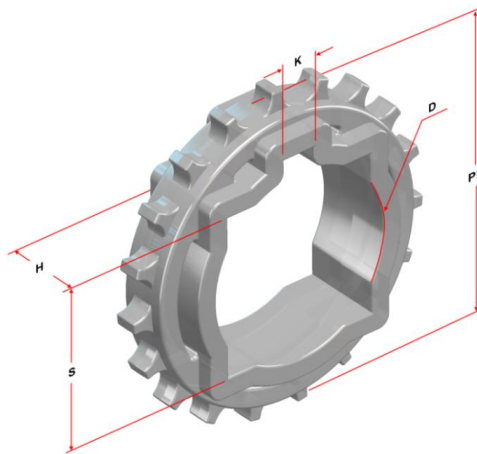

## Sprocket Dimensions

Unit: mm

No. Teeth	PD	OD	S	D	H	K
10	41.10	41	--	20/25	12	6X6
15	61.08	63	25/30	25	20	8X8
19	77.16	78	31.75/38.1/40	20/25/25.4/30/35	20	8X8
24	97.30	100.5	38.1/40	25.4/30	30	8X8
28	113.43	115	38.1/40	25/25.4/30/42.5	30	8X8