

HS-1400B Technical Data Sheet

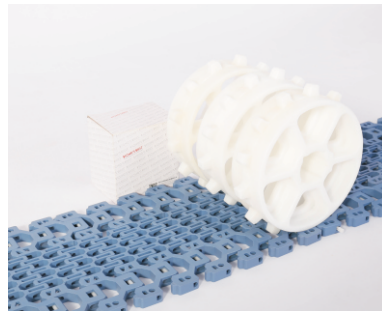
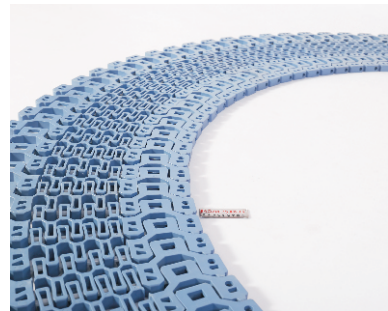
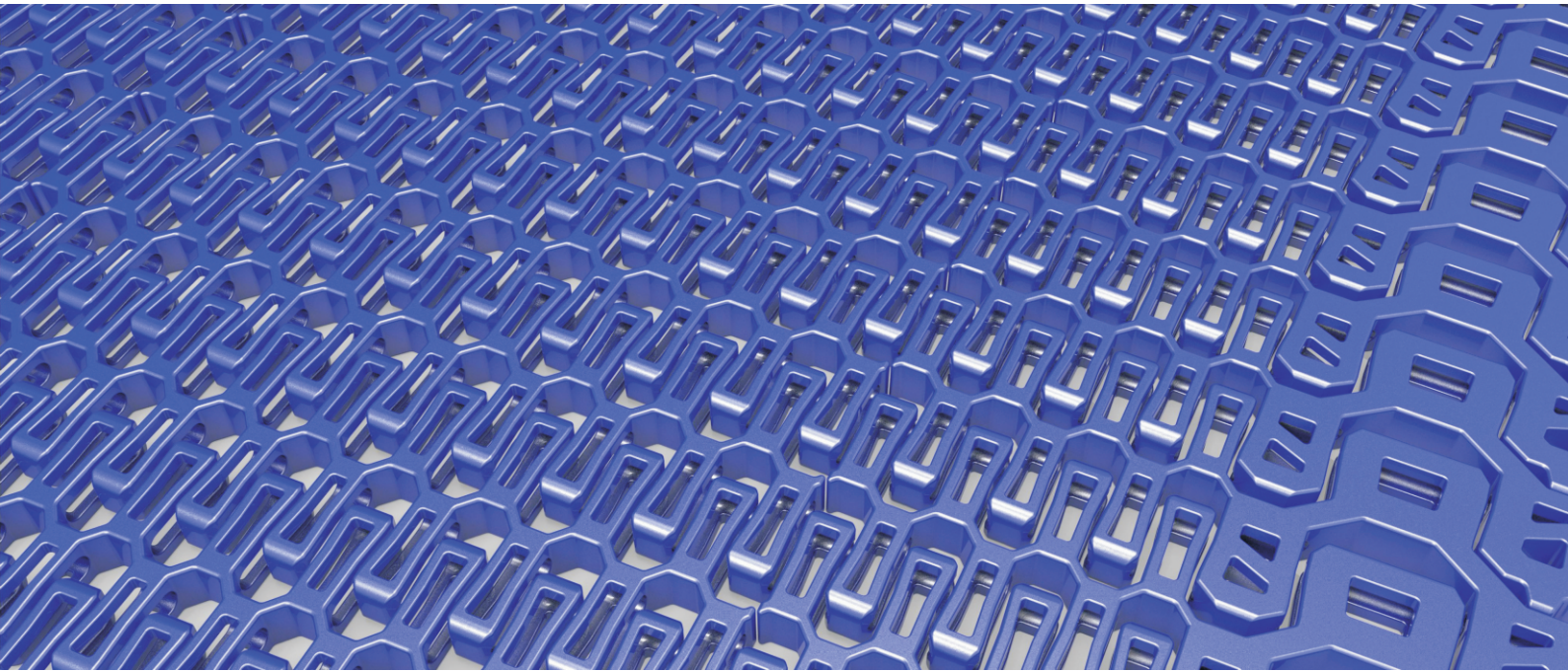

<p>Pitch : 50.8mm Minimum Width : 253mm Open Area : 63% Approved : FDA Rod : Ø 5.8mm Flight : No Side Guard : No Curve : Yes</p>	
---	--

Data

Belt Material	Belt Strength				Temperature		Belt Weight
	Straight		Curve		°C (min.)	°C (max.)	(Kg/M ²)
	Kg/M(BW)	N/M(BW)	Kg/M(BW)	N/M(BW)			
Acetal	3400	34000	340	3400	-40	80	8.7

BW – Belt Width

Color Table

Polypropylene					Polyethylene					Acetal					Nylon				
W	G	N	DB	B	W	G	N	DB	B	W	G	N	DB	B	W	G	N	DB	B
										●	●								

W-White, G-Gray, N-Nature, DB-Dark brown, B-Blue (For more information of belt color, pls consult our sales team)

Friction Table

Belt Material	Friction Wear strips & Products							
	UHMW	HDPE	Steel	Glass	SUS	Plastic	Cardboard	Aluminum
Polypropylene	0.32	0.24	0.15	0.09	0.13	0.08	0.15	0.25
Polyethylene	0.13	0.11	0.26	0.19	0.31	0.16	0.21	0.41
Acetal	0.11	0.09	0.27	0.16	0.26	0.15	0.19	0.28
Nylon	0.18	0.13	0.25	0.16	0.26	0.16	0.19	0.27

SUS – Stainless Steel

Equivalent type with other Brand

Brand Name	Intralox	Habasit	UNI	Renxord	MCC	ScanBelt
Series & Type	--	--	--	--	--	--

The above content is only for reference.

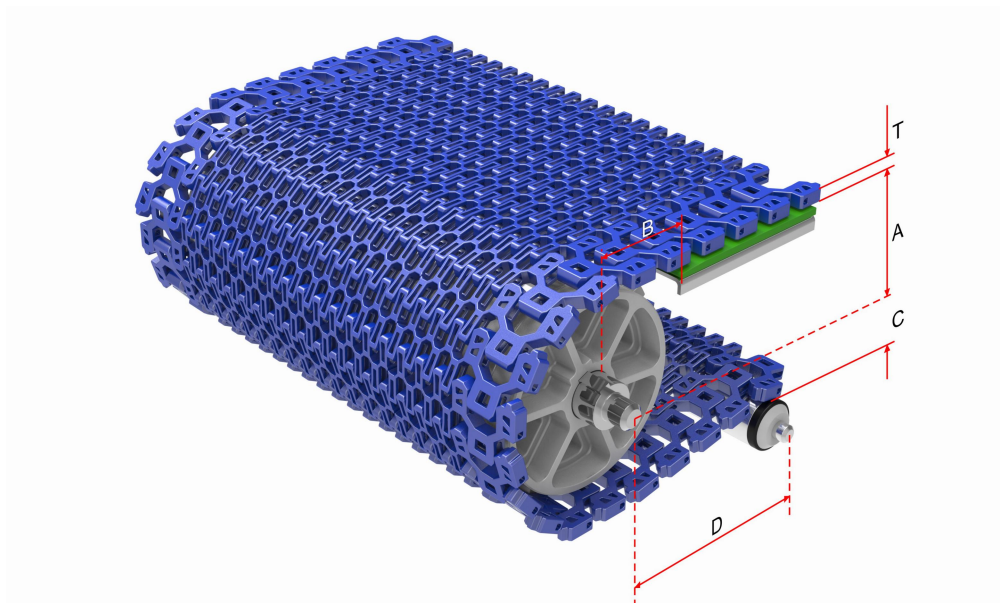

Conveyor Frame Dimensions

Unit : mm

No. Teeth	A (Min.)	B (Min.)	C (Max.)	D (Min.)	T
13	102.25	119.5	99	250	14.5

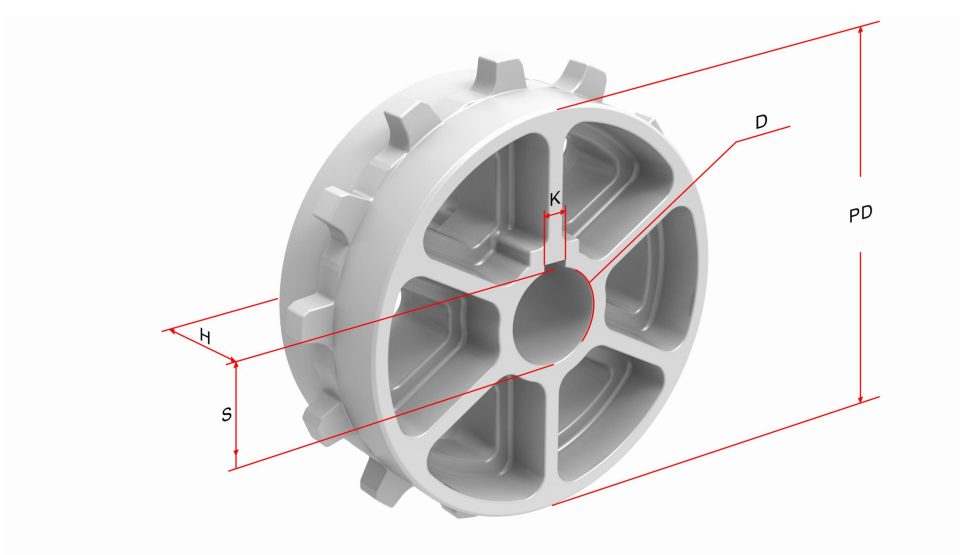

Sprocket Dimensions

Unit: mm

No. Teeth	PD	OD	S	D	H	K
13	196.28	219	38.1/40	45	76.2	8X8

Design Guide Summary

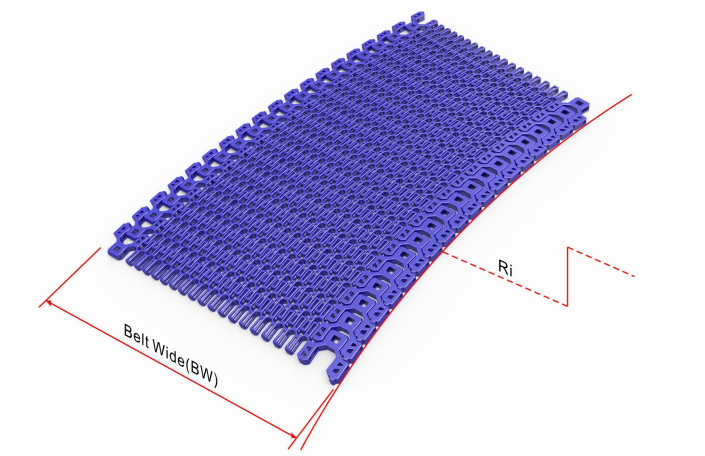

- The minimum turning radius (inside) is 2.2 times of belt width under all feasible belt Width, 2.5 times of belt width is the most optimal.
- The minimum straight run section near driving shaft and idling shaft of Radius belt must be 2 times of the belt width in length.
- The minimum straight run section between two turns of opposing direction must be 2 times of the belt width in length.

Guide Rail & Wear Strips

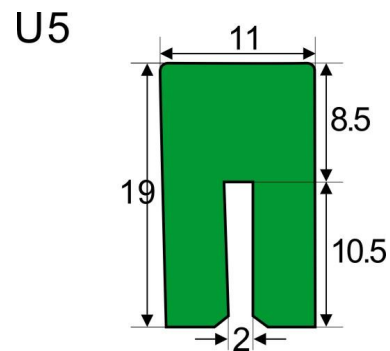
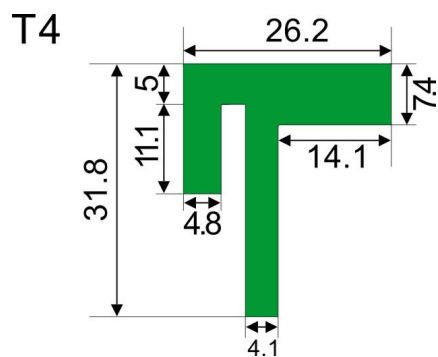
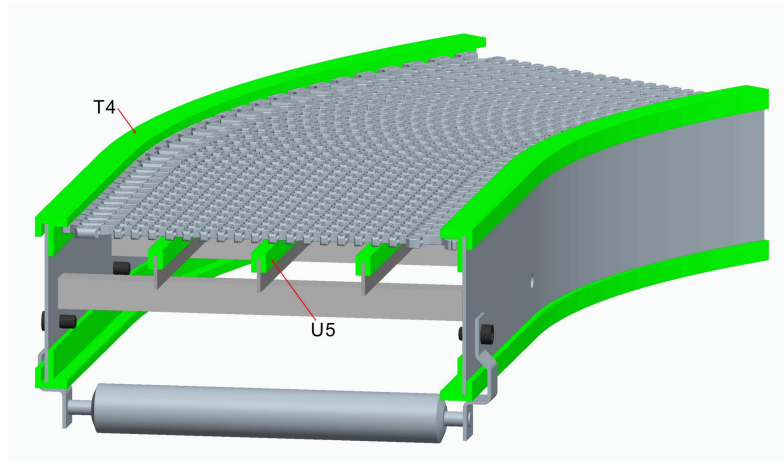

- We have different kinds of guide rail and wear strips for your choice; for more information, please consult our sales team.

