

# HS-1200B Technical Data Sheet

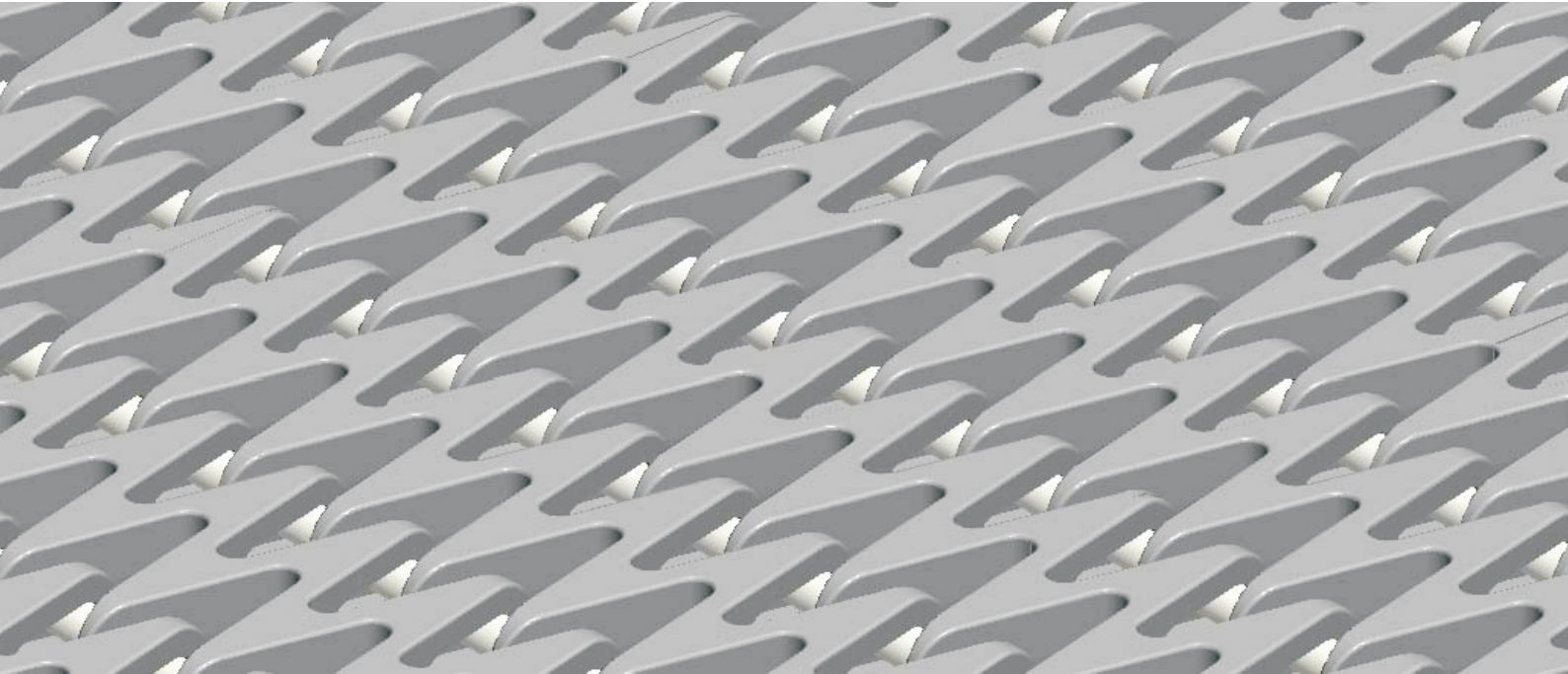

Pitch : 31.75mm Minimum Width : 230mm Open Area : 40% Approved : FDA Rod : Ø 4.9mm Flight : No Side Guard : No Curve : Yes	
---	--

## Data

Belt Material	Belt Strength				Temperature		Belt Weight (Kg/M <sup>2</sup> )
	Straight		Curve		°C (min.)	°C (max.)	
	Kg/M(BW)	N/M(BW)	Kg/M(BW)	N/M(BW)			
Polypropylene	1780	17800	178	1780	1	100	5.2
Polyethylene	1480	14800	148	1480	-60	60	5.5
Acetal	2200	22000	220	2200	-40	80	7.6

BW – Belt Width

## Color Table

Polypropylene					Polyethylene					Acetal					Nylon				
W	G	N	DB	B	W	G	N	DB	B	W	G	N	DB	B	W	G	N	DB	B
●	●						●			●			●	●					

W-White, G-Gray, N-Nature, DB-Dark brown, B-Blue (For more information of belt color, pls consult our sales team)

## Friction Table

Belt Material	Friction Wear strips & Products							
	UHMW	HDPE	Steel	Glass	SUS	Plastic	Cardboard	Aluminum
Polypropylene	0.32	0.24	0.15	0.09	0.13	0.08	0.15	0.25
Polyethylene	0.13	0.11	0.26	0.19	0.31	0.16	0.21	0.41
Acetal	0.11	0.09	0.27	0.16	0.26	0.15	0.19	0.28
Nylon	0.18	0.13	0.25	0.16	0.26	0.16	0.19	0.27

SUS – Stainless Steel

## Equivalent type with other Brand

Brand Name	Intralox	Habasit	UNI	Rexnord	MCC	ScanBelt
Series & Type	--	--	--	--	--	--

The above content is only for reference.

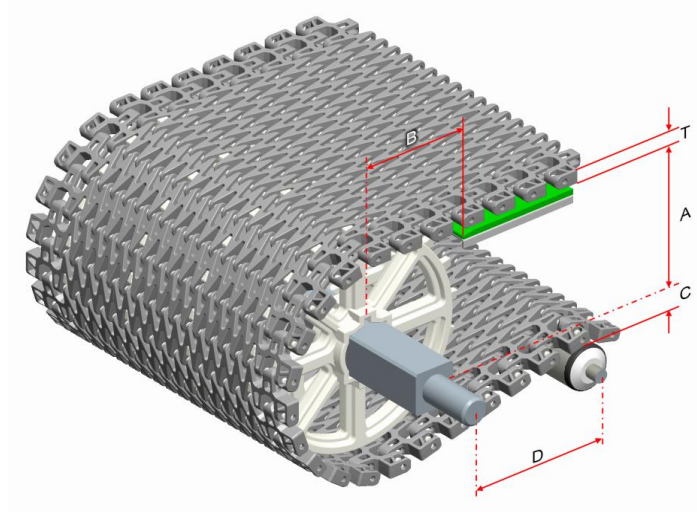

**Conveyor Frame Dimensions**

Unit : mm

No. Teeth	A ( Min.)	B ( Min.)	C ( Max.)	D ( Min.)	T
12	57.25	73.25	55.25	250	12
16	78	94	76	250	

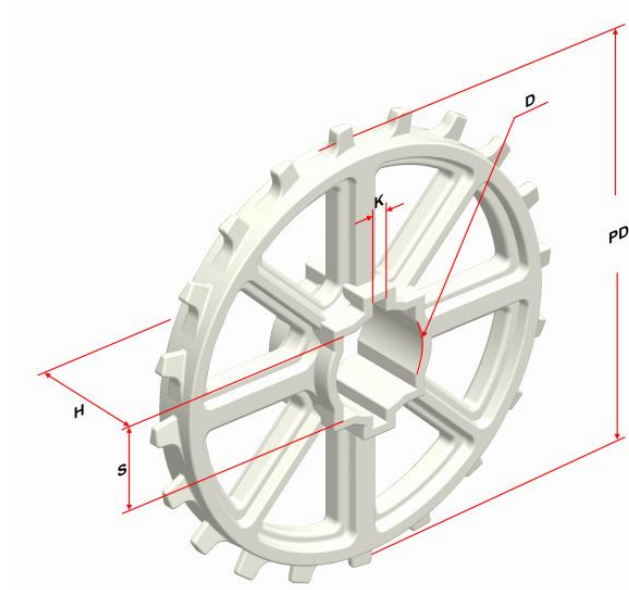

**Sprocket Dimensions**

Unit: mm

No. Teeth	PD	OD	S	D	H	K
12	122.67	126.5	38.1/40	--	38	--
16	162.75	168	38.1/40	--	30	--

## Design Guide Summary

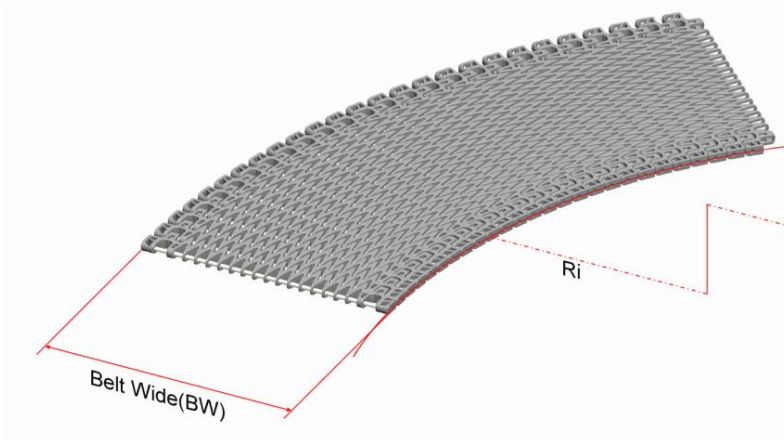

- The minimum turning radius (inside) is 2.2 times of belt width under all feasible belt Width, 2.5 times of belt width is the most optimal.
- The minimum straight run section near driving shaft and idling shaft of Radius belt must be 2 times of the belt width in length.
- The minimum straight run section between two turns of opposing direction must be 2 times of the belt width in Length.

## Guide Rail & Wear Strips

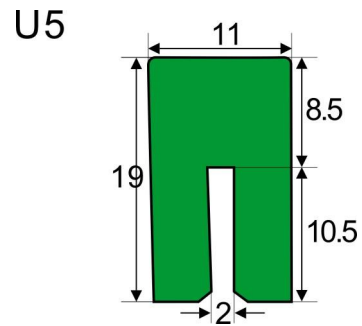
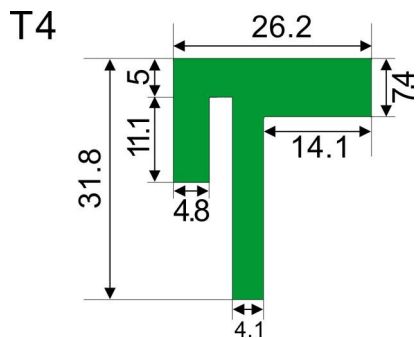
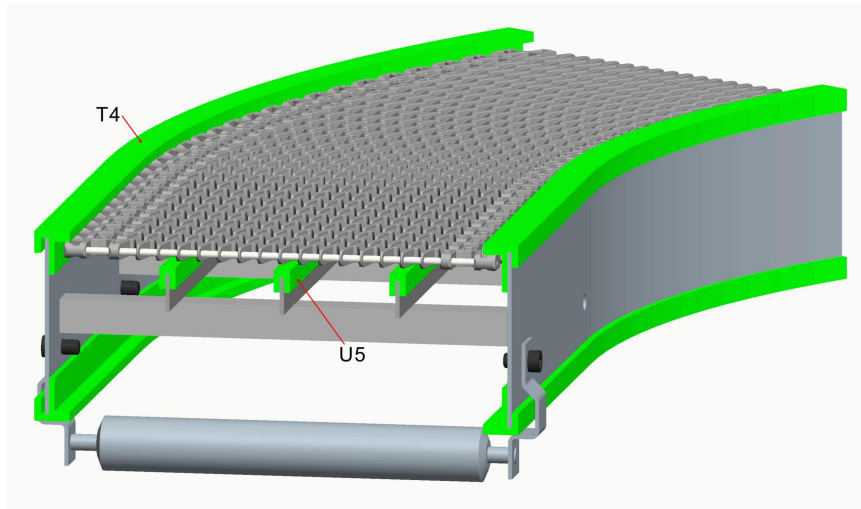

- We have different kinds of guide rail and wear strips for your choice; for more information, please consult our sales team.

