

HS-100A-HD-N-C Technical Data Sheet

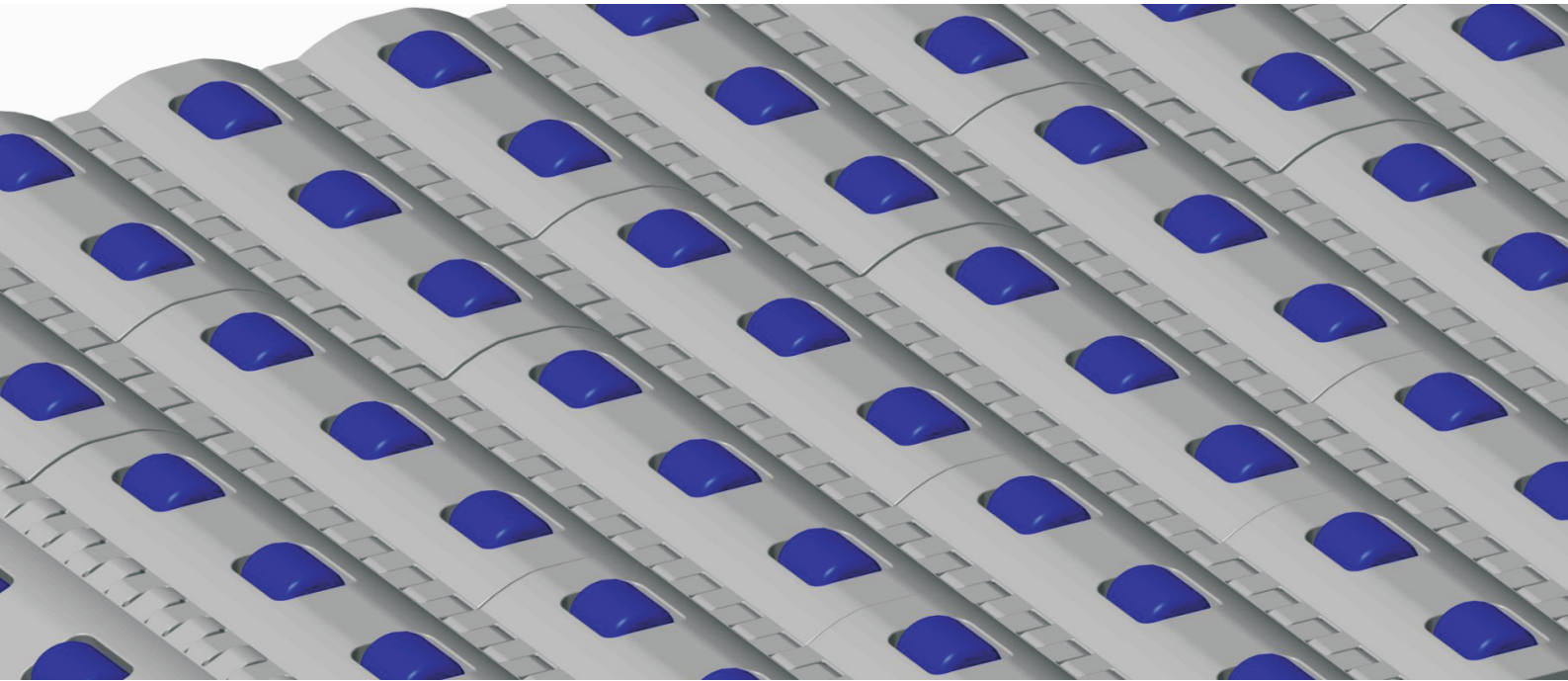

<p>Pitch: 50.8mm Minimum Width: 251mm Open Area: 3% Approved: FDA Rod: Ø 5.8mm Flight: No Side Guard: No Curve: No</p>	
---	--

Data

Belt Material	Belt Strength			Temperature		Belt Weight
	Straight		Curve	°C (min.)	°C (max.)	(Kg/M ²)
	Kg/M(BW)	N/M(BW)				
Polypropylene	1340	13400	--	1	100	14.5
Acetal	1770	17700	--	-40	80	20.5

BW – Belt Width

Color Table

Polypropylene					Polyethylene					Acetal					Nylon				
W	G	N	DB	B	W	G	N	DB	B	W	G	N	DB	B	W	G	N	DB	B
●	●						●			●				●				●	

W-White, G-Gray, N-Nature, DB-Dark brown, B-Blue (For more information of belt color, pls consult our sales team)

Friction Table

Belt Material	Friction Wear strips & Products							
	UHMW	HDPE	Steel	Glass	SUS	Plastic	Cardboard	Aluminum
Polypropylene	0.32	0.24	0.15	0.09	0.13	0.08	0.15	0.25
Polyethylene	0.13	0.11	0.26	0.19	0.31	0.16	0.21	0.41
Acetal	0.11	0.09	0.27	0.16	0.26	0.15	0.19	0.28
Nylon	0.18	0.13	0.25	0.16	0.26	0.16	0.19	0.27

SUS – Stainless Steel

Equivalent type with other Brand

Brand Name	Intralox	Habasit	UNI	Rexnord	MCC	ScanBelt
Series & Type	S800 Roller Top	--	--	--	--	--

The above content is only for reference.

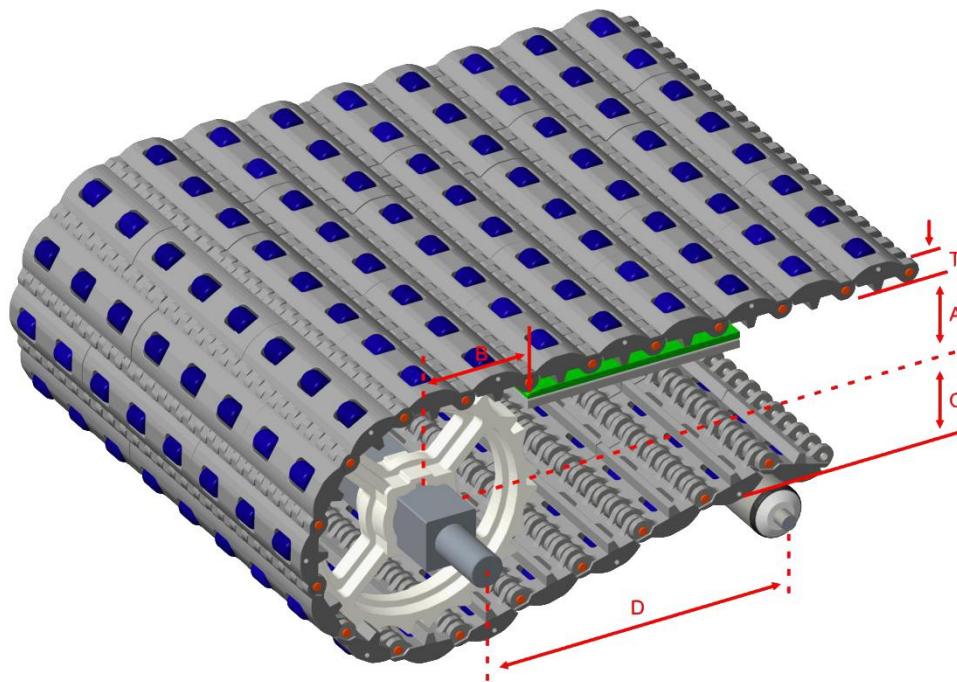

Conveyor Frame Dimensions

Unit : mm

No. Teeth	A (Min.)	B (Min.)	C (Max.)	D (Min.)	T	T1
6	33.05	54.55	25.55	250	23	3.5
6/N	36.6	58.1	29.1	250		
8 / 8/N	50.15	71.65	42.65	250		
10 / 10/N	67.15	88.65	59.65	250		
12 / 12/N	83.9	105.4	76.4	300		
16 / 16/N	115.35	136.85	107.85	300		

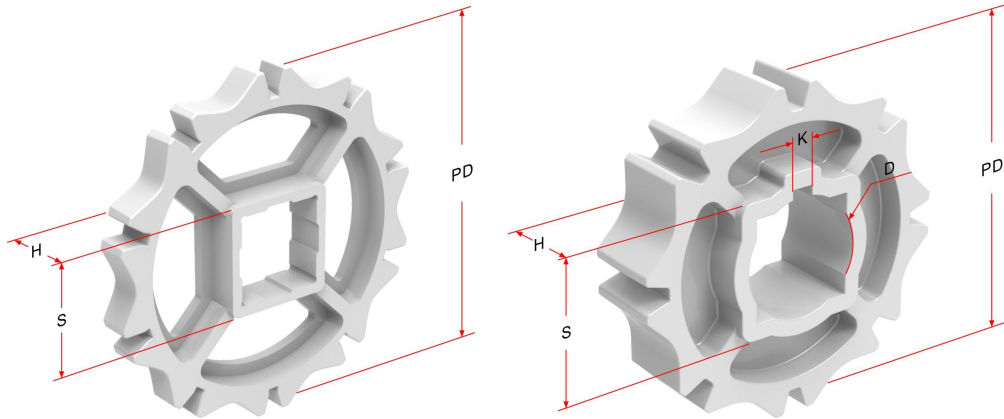

Sprocket Dimensions

Unit: mm

No. Teeth	PD	OD	S	D	H	K
6	101.60	89.1	25.4/38.1/40	25.4/30/45	37	8X8
8	132.75	123.3	38.1/40	25.4/30	37	6.35X3.17
10	164.39	157.2	38.1/40	30	37	8X8
12	196.28	190.8	38.1/40/50/60	--	37	--
16	260.39	253.7	--	25.4	37	8X8

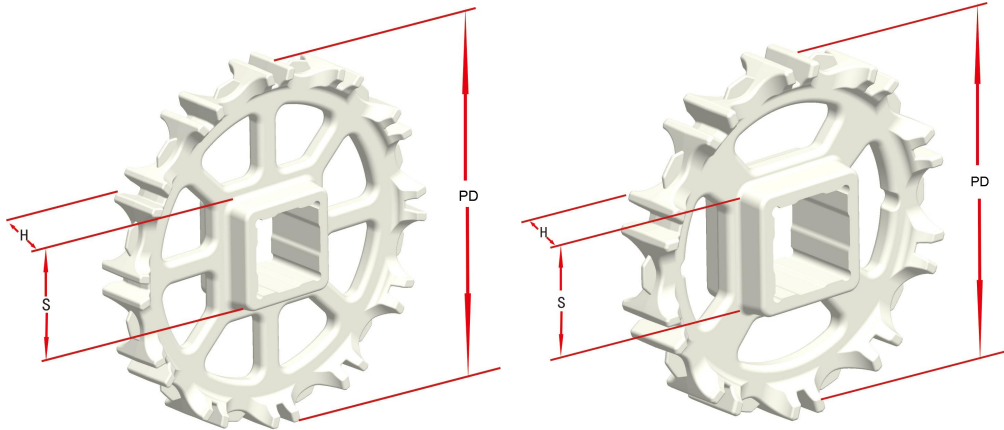

Sprocket Dimensions

Unit: mm

No. Teeth	PD	OD	S	D	H	K
6/N	101.60	96.2	25.4/38.1/40	25.4/31.75/38.1	37	6.35X3.17
8/N	132.75	123.3	38.1/40	25.4/25.5/30/31.75	37	6.35X3.17
10/N	164.39	157.3	38.1/40/50.8/60	25.4/30/31.75/35/36/38.1/50/50.8	37	6.35X3.17
12/N	196.28	190.8	38.1/40/60	--	37	--
16/N	260.39	253.7	38.1/40/60/63.5	25	37	8X8