

HS-1000AB-76 Technical Data Sheet

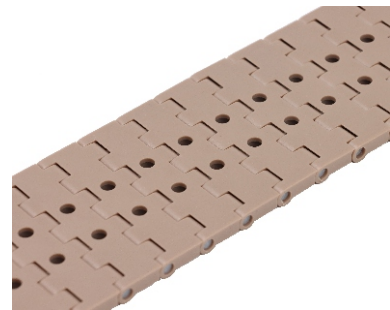

HONG'S BELT
Smart Conveyor System Solutions

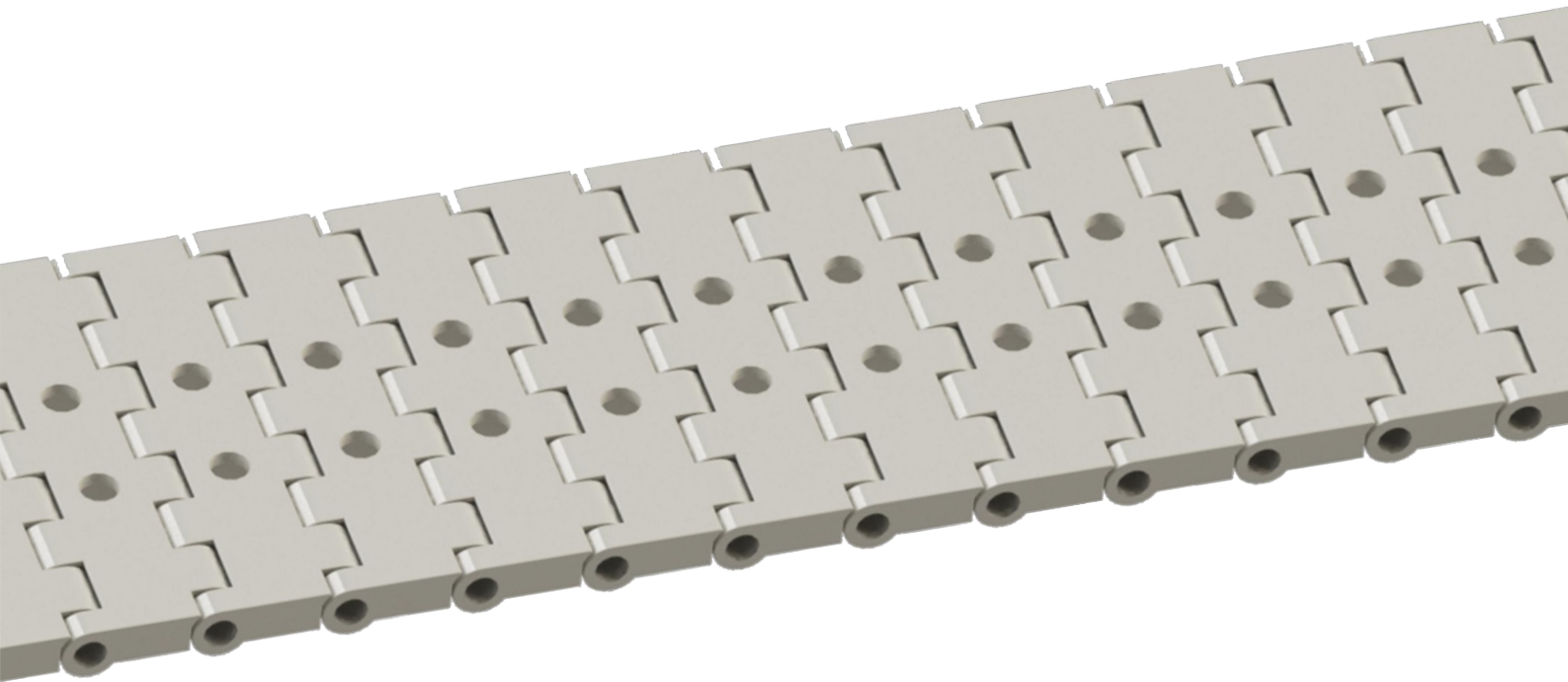
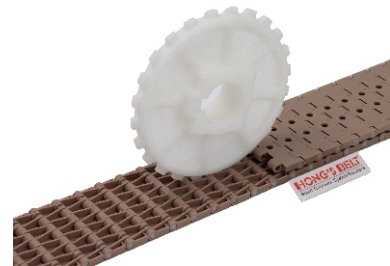
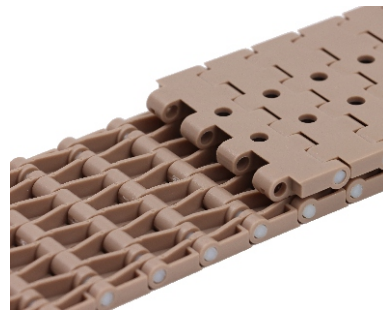

HONG'S BELT
Smart Conveyor System Solutions

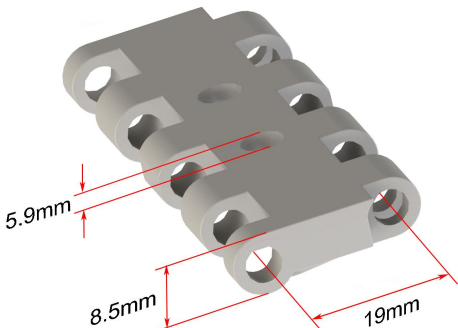
Pitch : 19mm Minimum Width : 76mm Open Area : 2% Approved : FDA Rod : Ø 4.5mm Flight : No Side Guard : No Curve : No	
---	--

Data

Belt Material	Belt Strength			Temperature		Belt Weight (Kg/M)
	Straight		Curve	°C (min.)	°C (max.)	
	Kg/M(BW)	N/M(BW)				
Polypropylene	1420	14200	--	1	100	0.35
Polyethylene	1210	12100	--	-60	60	0.36
Acetal	2025	20250	--	-40	80	0.49
Nylon	1500	15000	--	1	180	0.37

BW – Belt Width

Color Table

Polypropylene					Polyethylene					Acetal					Nylon				
W	G	N	DB	B	W	G	N	DB	B	W	G	N	DB	B	W	G	N	DB	B
●	●						●			●						●			

W-White, G-Gray, N-Nature, DB-Dark brown, B-Blue (For more information of belt color, pls consult our sales team)

Friction Table

Belt Material	Friction Wear strips & Products							
	UHMW	HDPE	Steel	Glass	SUS	Plastic	Cardboard	Aluminum
Polypropylene	0.32	0.24	0.15	0.09	0.13	0.08	0.15	0.25
Polyethylene	0.13	0.11	0.26	0.19	0.31	0.16	0.21	0.41
Acetal	0.11	0.09	0.27	0.16	0.26	0.15	0.19	0.28
Nylon	0.18	0.13	0.25	0.16	0.26	0.16	0.19	0.27

SUS – Stainless Steel

Equivalent type with other Brand

Brand Name	Intralox	Habasit	UNI	Rexnord	MCC	ScanBelt
Series & Type	--	--	--	--	--	--

The above content is only for reference.

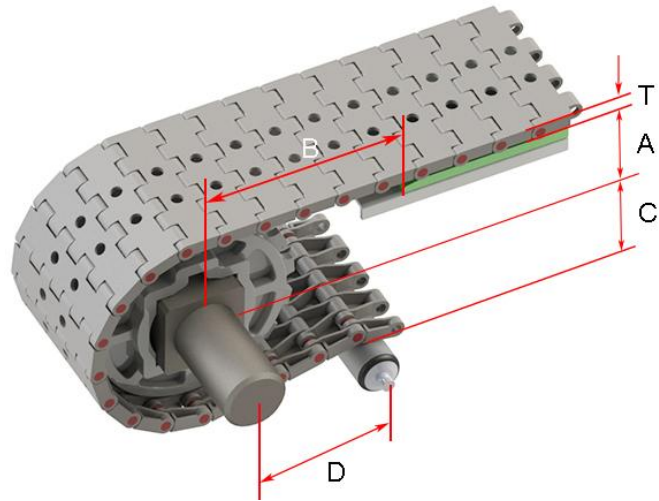

Conveyor Frame Dimensions

Unit : mm

No. Teeth	A (Min.)	B (Min.)	C (Max.)	D (Min.)	T
7	17	31.25	16.75	200	8.5
10	26.25	40.5	26	200	
17	47.5	61.75	47.25	200	
24	68.5	82.75	68.25	250	

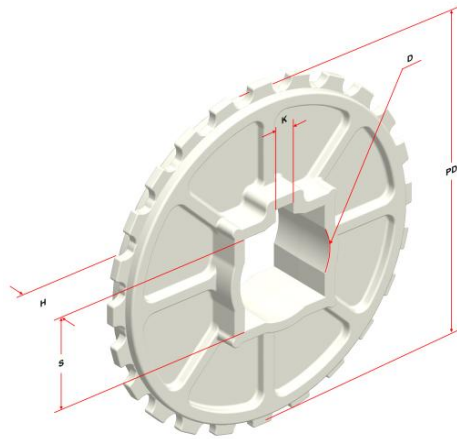

Sprocket Dimensions

Unit: mm

No. Teeth	PD	OD	S	D	H	K
7	43.79	42.5	--	20/25	12	6X6
10	61.49	61	--	25	20	8X8
17	103.40	103.5	38.1/40	25.4/30/31.75/40/45/47	30	8X8
24	145.56	145.5	38.1/40	25.4/30/35/38/40/45	30	8X8